

# For movement in precision.

Small bearings, special bearings and miniature bearings.



**ZWICKER**  
**PRECISION BEARINGS**

Teamwork guarantees performance!

The Künemund Group comprises manufacturing companies, trading enterprises and a computer centre. All of the companies are networked with each other and are ready to meet your tasks with bundled expertise.

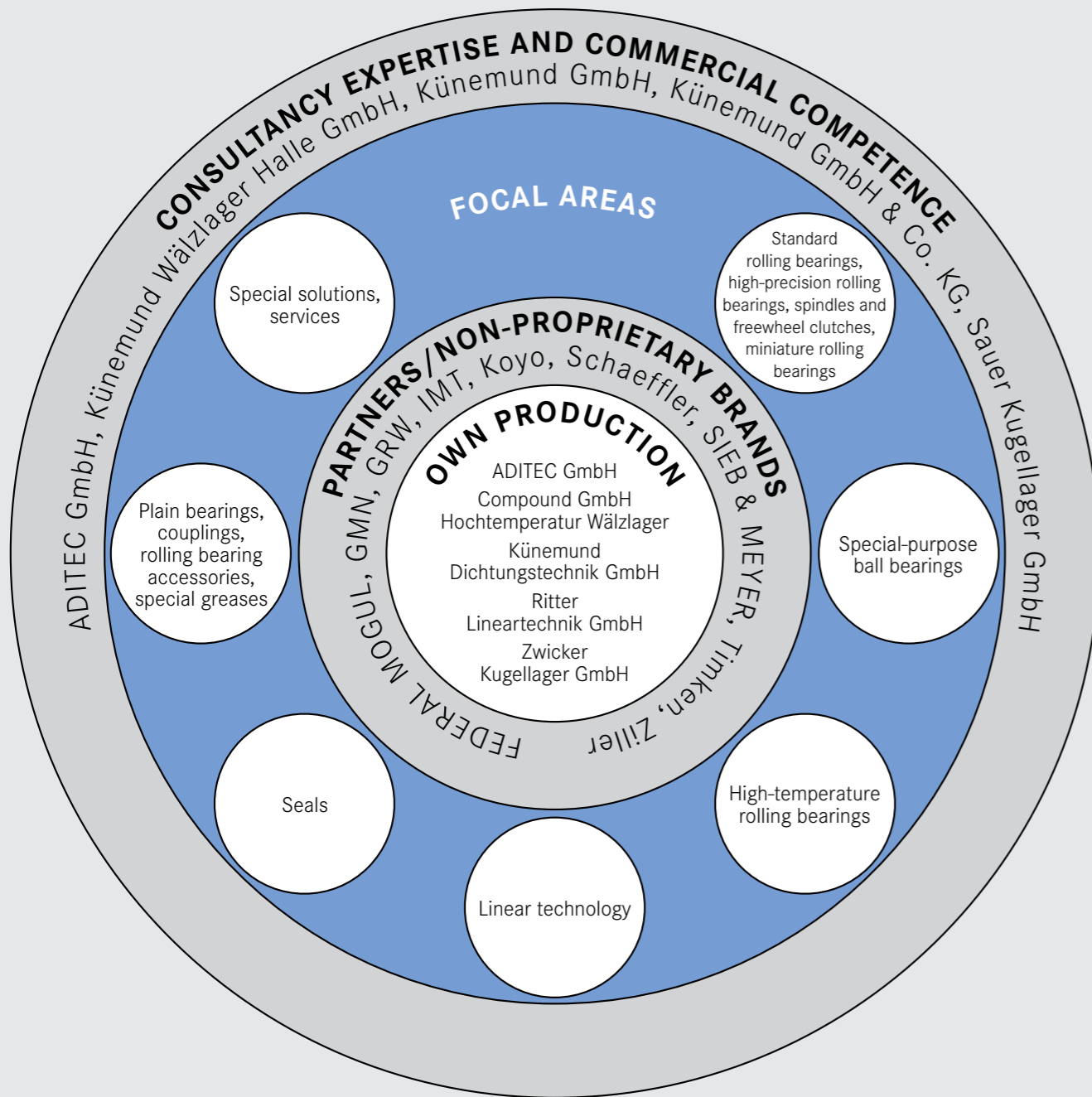

The Zwicker ball bearing company was founded in 1927 in Esslingen a. N. by Christian Zwicker, a master of mechanics. After 50 years at the habitat Esslingen, Hans and Rolf Zwicker moved the factory to Schoellnach in the Bavarian Forest, easily accessible via the highways A3 and A92.

Even though every day several thousands of ball bearings leave our production, we have become more and more a manufacturer of specialties, adapted precisely to the requirements and usage of the customer.

Current investment in a flexible production, well trained and motivated co-workers as well as long-time engagement to a sub company in the Czech Republic ensure a delivery on time with reasonably priced and high-quality products. Trustful co-operation with other manufacturers of ball bearings world wide has been established for many years and provides us with the possibility to conduct even bigger orders without any problems.

As one of the producing companies inside the Künemund Group we are pleased that our products and our flexibility is appreciated by leading companies of most different industries.

Bernd Zwicker  
 Managing Director

Small ball bearings, thin-section bearings and special-purpose ball bearings from Zwicker Kugellager GmbH are used in many areas of industry, from medical engineering and the electric motor industry to the broad spectrum of mechanical engineering. The focal areas of production are precision ball bearings with bore diameters from 4 mm to 25 mm. Our customers particularly value the flexible manufacturing offered by Zwicker.

**Off-the-peg solutions don't always suit. That's why we produce more than just standard.**

Thomas Sigl, turning shop and toolmaking foreman, and Silvia Kirsten, shipping and assembly, Zwicker Kugellager GmbH

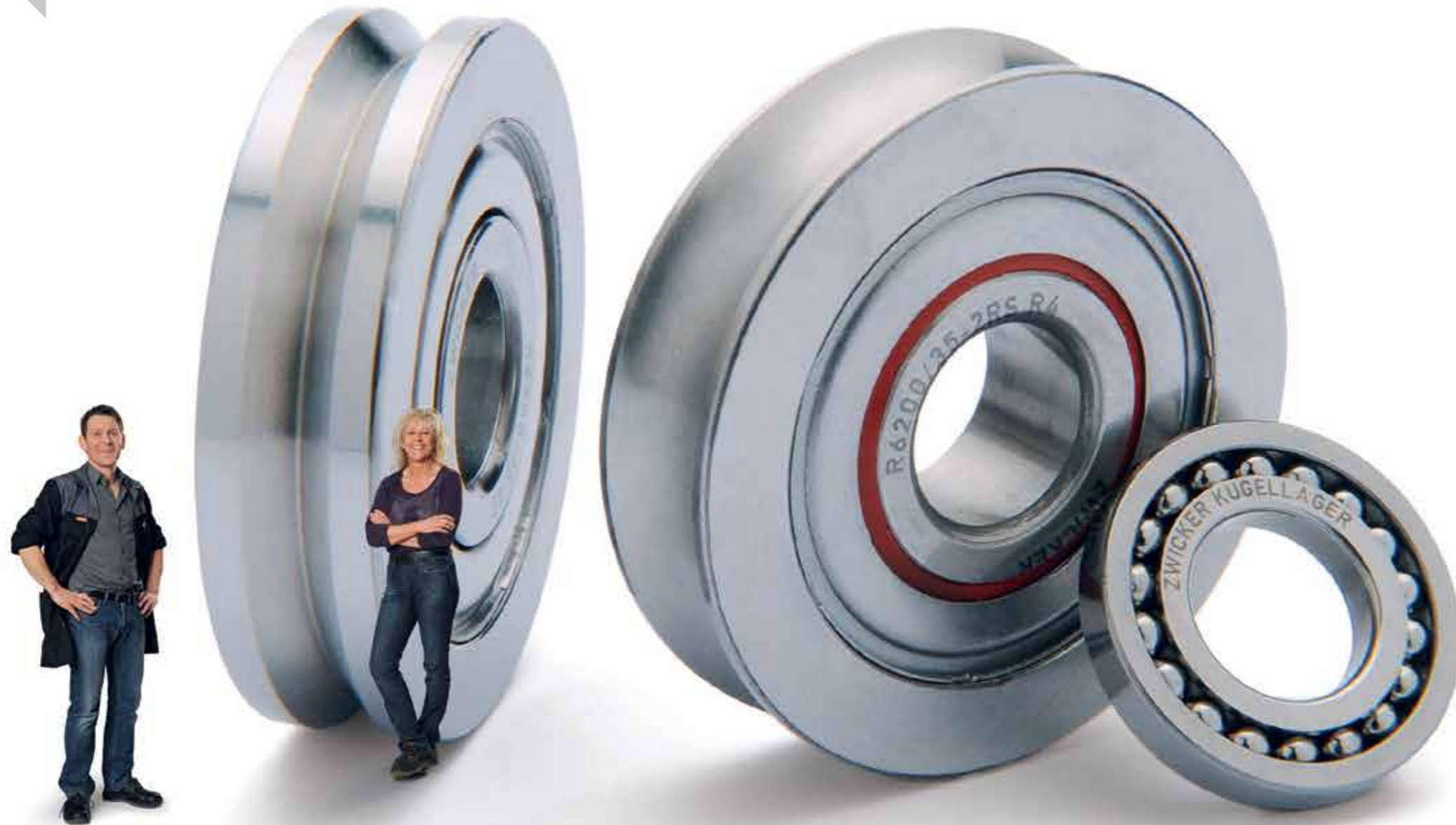

### Products

- Deep-groove ball bearings with bore diameters from 4 mm to 25 mm, with various shields and seals, cages, lubricating greases or oils
- Bearings for prosthetics
- Bearing units
- Special-purpose bearings according to drawing

### Services designed for you

#### Failure analysis

- Assessment of current condition on site
- Failure and condition analyses
- Microscopic examinations
- Recommendation and calculation of new bearing designs taking into account the entire bearing arrangement (bearings, sealing, lubrication and mating parts)

#### Design support

- Bearing design for newly designed machines
- Recommendation of lubricants
- Calculation of relubrication intervals, calculation of required operating clearances
- Calculation of service life



Zwicker Kugellager GmbH, based in Schöllnach, is a Künemund Group company. Its focus is on the production of special-purpose ball bearings precisely matched to the customer's needs and applications.

## Index

Program overview, designation code	7
Delivery versions	8
Technical information	10
Versions of cages and seals	14
Internal clearance, fittings, rotational speed	16
Toleranzen der Umbauteile	17
Lubrication, oil lubrication	18
Grease lubrication	19
Matched bearings	20
The Künemund Group	22

All information, data and dimension tables in this catalogue have been compiled carefully and have been thoroughly checked. However, no responsibility for possible errors or omissions can be assumed. We reserve the right to change specifications and other information included in this catalogue without notice. All rights reserved. Copying, even in parts, requires our prior approval.

© Zwicker Kugellager GmbH. Edition 2013.

## Program overview, designation code

### Program overview

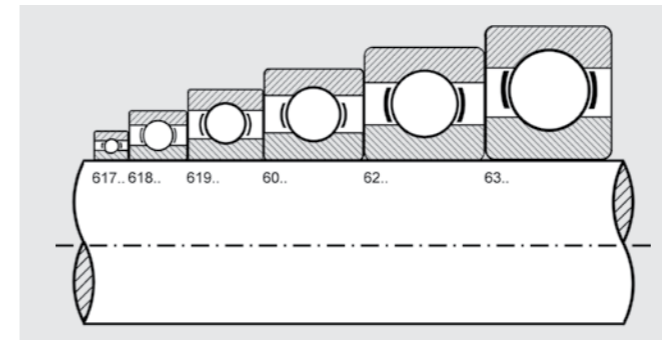

The single row radial contact ball bearing is the most common rolling bearing. Besides the type series in compliance with boundary dimensions according to ISO 15, ball bearings other than the given values are also produced as miniature bearings, track rollers, wire alignment ball bearings and more special bearings. Further there are ball bearings in inch measurements in our program, which are oriented towards the ABMA/ANSI – boundary dimensions. Single row metric radial contact ball bearings according to DIN 625 are produced as series 617 ..., 618 ..., 619 ..., 60 ..., 62 ... and 63 ... . A comparison between the boundary dimensions is shown in the chart above.

Being a German manufacturer of quality products, we have focussed our business on the demands of our clients. A few special products emerged from close co-operation during product planning, which offer our customers crucial advantages concerning load capacity, endurance, temperature stability and reliability of their products. No matter if bearing pairs, multiple arrangements, special bearings made from special materials or ready to mount bearing units, for many customers we have been an essential partner for decades where small or medium batch sizes in highest quality are of concern.

Some of these special types have become a part of the catalogue program because of high market demands, such as our track rollers with an outside diameter up to 62 mm and wire straightening ball bearings R6 ... with an outside diameter up to 47 mm. These have a 90° annular groove by default but are also available with ground radii and other special designs on demand.

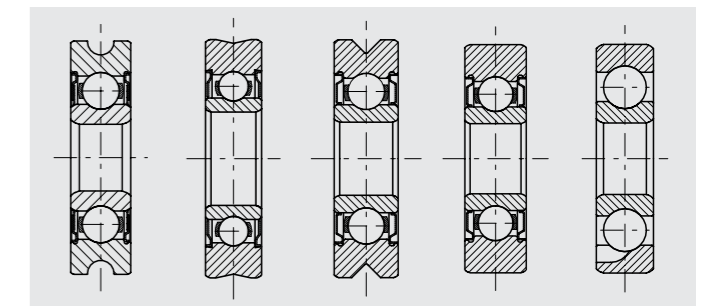

We are glad to offer you our application engineering service for the choice of the proper bearing.

### Designation code

1	2	3	4	5	6	7	8	9	10	11
HY	6201	/d12,7	-2RS	N	T9H	P6	C3	G1	NB52	20%

1	F HY LR R S	flanged ball bearings hybrid bearings, rings and balls made from different materials track rollers, pulleys wire straightening ball bearings ball bearings made from materials with high corrosion resistance
2	6201 R8	identification according to DIN623/DIN625 basic identification for bearings in inch measurements
3	d, D, B, R	measures deviating from standard
4	Z RS RZ RU BRS URS VS	non-contact shield made from sheet steel Contact seal made from steel armoured NBR non-contact shield made from steel armoured NBR non-contact seal made from steel armoured NBR non-contact seal made from steel armoured NBR contact seal made from steel armoured NBR High temperature contact seal, steel armoured FPM
5	N, NR NB, NBR	annular groove in outer ring, for NR with added snap ring like N/NR, but annular groove and closure on the same side
6	J Y T9H TXH TBH	two-part ribbon steel cage, standard cage, not indicated two-part ribbon brass cage one-part ball guided crown cage from PA66GF one-part ball guided crown cage from PEEKGF one-part, inner land guided phenolic crown cage, fibre reinforced
7	PN P6, P5, P4	precision class PN according to DIN620T2, not indicated higher precision classes according to DIN620T2
8	C ... C0/3 R ... - ... μ	radial internal bearing clearance according to DIN620T4, see page 16 optimized internal bearing clearance according to Zwicker factory standard specified radial clearance, available on request
9	G ...	matched deep groove ball bearing, see page 20
10/11		special lubricant and quantity, see page 18

Delivery versions

	Open-type	Z	RS	RJ/RZ	BRS	URS	VS (Fluorelastomer)	CN, C3	C2	C1, C4, C5	Specified radial clearance	J-retainer	Y-retainer	TBH-retainer	T9H-retainer	TXH-retainer	P5	P4	Special lubrication	Matched G1, G2	Matched G3	Universally matched	Wire straightening bearings	Reinforced outer ring	Convex outer ring	Inch sized bore diameter	Full ball complement	Hybrid versions	
623	x	x	o					x	x	x	x	x	o	o			x	o	x				x	o	o		o	o	
618/4	x							x	o	o	o	x					o		x		o							o	o
628/4+ 638/4	x	x	x					x	o	o	o	x					o		x		o							o	o
619/4	x	x	x					x	o	o	o	x					o		x		o							o	o
604	x	x	x					x	x	x	x	x		x			x		x	o	o	o	x	o	o			o	o
624	x	x	x					x	x	x	x	x	o	x			x	o	x	x	x	o	x	o	o			o	o
634	x	x	x					x	x	x	x	x	x	x			x	x	x	x	x	o	x	o	o			o	o
618/5	x							x	o	o	o	x		o			o		x		o							o	o
628/5+ 638/5	x	x	x					x	o	o	o	x		o			o		x		o							o	o
619/5	x	x	x					x	o	o	o	x		x			o		x		o							o	o
605	x	x	x					x	o	o	o	x		x			o		x		o		x	o	o			o	o
625	x	x	x					x	x	x	x	x	o	x			x	x	x	x	x	o	x	o	o			o	o
635	x	x	x		x		x	x	x	x	x	x	o	x	x	x	x	x	x	x	x	o	x	x	o			o	o
618/6	x							x	x	x	x	x		o			o	o	x		o							o	o
628/6	x	x	o					x	x	x	x	x		o			o	o	x		o							o	o
619/6	x	x	x					x	o	o	o	x					o	o	x		o							o	o
606	x	x	x					x	x	x	x	x		x			x	o	x	x	x	o	x	o	o			o	o
626	x	x	x		x		x	x	x	x	x	x	o	x	x	x	x	x	x	x	x	o	x	x	o	o		o	o
618/7	x							x	x	x	x	x		o			o	o	x		o	x						o	o
628/7	x	x	x					x	x	x	x	x		o			o	o	x		o	x						o	o
619/7	x	x	o					x	x	x	x	x		x			o	o	x		o	x						o	o
607	x	x	x		x		x	x	x	x	x	x	o	x	x	x	x	x	x	x	x	o	x	x	o			o	o
627	x	x	x	x	x	x	x	x	x	x	x	x	o	x	x	x	x	x	x	x	x	o	x	x	o			o	o
618/8	x							x	x	x	x	x		o			o	o	x		o	x						o	o
628/8+ 638/8	x	x	x	o				x	x	x	x	x		x			o	o	x		o	x						o	o
619/8	x	x	x				x	x	x	x	x	x	o	x	o	x	x	x	x	x	x	o	x	x	o			o	o
608	x	x	x	x	x	x	x	x	x	x	x	x	o	x	x	x	x	x	x	x	x	o	x	x	o	o		o	o
628	x	x	x					x	o	o	o	x					x	o	x	x	x	o						o	o
618/9	x							x	x	x	x	x		o			o	o	x		o	x						o	o
628/9	x	x	x					x	x	x	x	x		o			o	o	x		o	x						o	o
619/9	x	x	o					x	x	x	x	x		o			o	o	x		o	x						o	o
609	x	x	x					x	x	x	x	x	o	x			x	x	x	x	x	o		o	o			o	o
629	x	x	x	x	o	o	x	x	x	x	x	x	o	x	x		x	x	x	x	x	o	o	x	o			o	o
61800	x	x	x	x				x	x	x	x	x		o	x		x	x	x	x	x	o						o	o
62800/ 63800	x	x	o	o				x	x	x	x	x		o			x	x	x	x	x	o						o	o
61900	x	x	x	x				x	x	x	x	x	o	x			x	x	x	x	x	o	x	x	o	o	o	o	o
6000	x	x	x	x	x	x	x	x	x	x	x	x	o	x	x		x	x	x	x	x	o	x	x	o	o	o	o	o
16100	x	x	x					x	x	x	x	x	o	x			x	x	x	x	x	o		x	o			o	o
6200	x	x	x		o		o	x	x	x	x	x	x	x	x		x	x	x	x	x	o	x	x	o	o	o	o	o
6300	x	x	o					x	x	x	x	x	x	x			x	x	x	x	x	o		o				o	o
61801	x	x	x	x				x	x	x	x	x		o	x		x	x	x	x	x	o						o	o
62801/ 63801	x	x	o	o				x	x	x	x	x		o			x	x	x	x	x	o						o	o
61901	x	x	x	x				x	x	x	x	x		x			x	x	x	x	x	o			o			o	o

x = available on short call, o = please request delivery time and possibility

Delivery versions

	Open-type	Z	RS	RJ/RZ	BRS	URS	VS (Fluorelastomer)	CN, C3	C2	C1, C4, C5	Specified radial clearance	J-retainer	Y-retainer	TBH-retainer	T9H-retainer	TXH-retainer	P5	P4	Special lubrication	Matched G1, G2	Matched G3	Universally matched	Wire straightening bearings	Reinforced outer ring	Convex outer ring	Inch sized bore diameter	Full ball complement	Hybrid versions	
6001	x	x	x	x	x	o	x	x	x	x	x	x	o	x	x	x	x	x	x	x	x	o			x		o	o	
16101	x	x	x					x	x	x	x	x	o	x			x	x	x	x	x	o			x		o	o	
6201	x	x	x	x	x	x	x	x	x	x	x	x	x	x	x	x	x	x	x	x	x	o	x	x	x		o	o	
6301	x	x	x		o			x	x	x	x	x		x	x		x	x	x	x	x	o						o	o
61802	x	x	x	x				x	x	x	x	x		o	x		x	x	x	x	x	o						o	o
62802/ 63802	x	x	o	o				x	x	x	x	x		o			x	x	x	x	x	o						o	o
61902	x	x	x	x				x	x	x	x	x		x			x	x	x	x	x	o			o			o	o
16002	x	x	o					x	x	x	x	x	o	x			x	x	x	x	x	o			o			o	o
6002	x	x	x	x	x	x	x	x	x	x	x	x	o	x	x		x	x	x	x	x	o			o	o		o	o
6202	x	x	x		x	x	x	x	x	x	x	x	o	x	x	x	x	x	x	x	x	o	x	x	o	x		o	o
6302	x	x				x		x	x	x	x	x		x			x	x	x	x	x	o						o	o
61803	x	x	x	x				x	x	x	x	x		o			x	x	x	x	x	o						o	o
62803/ 63803	x	x	o	o				x	x	x	x	x		o			x	x	x	x	x	o						o	o
61903	x	x	x	x				x	x	x	x	x		x			x	x	x	x	x	o			o			o	o
16003	x	x	o					x	x	x	x	x		x	x		x	x	x	x	x	o			o			o	o
6003	x	x	x	x	x		x	x	x	x	x	x		x	x		x	x	x	x	x	o			o			o	o
6203	x	x	x	x	x	x	x	x	x	x	x	x		x	x	x	x	x	x	x	x	o			o	x		o	o
6303	x	x				x		x	o	o	o	x					x	x	x	x	x	o						o	o
61804	x	x	x	x				x	x	x	x	x		o	o		x	x	x	x	x	o						o	o
61904	x	x	x	x				x	o	o	o	x		o			x	o	o	o	o	o						o	o
6004	x	x	x	x			x	x	x	x	x	x		x	x	x	x	x	x	x	x	o			o			o	o
6204	x	x	x	x	o	x	x	x	x	x	x	x		x	x		x	x	x	x	x	o			o			o	o
6304	x	x			x	x		x	o	o	o	x					x	x	x	x	x	o						o	o
61805	x	x	x	x				x	o	o	o	x					x		o	o	o	o						o	o
61905	x	x	x	x				x	o	o	o	x					x		o	o	o	o						o	o
6005	x	x	x	x			x	x	x	x	x	x		x	x		x	x	x	x	x	o			o			o	o
6205	x	x	o				o	x	x	x	x	x		x	o		x	x	x	x	x	o			o			o	o
6305	x	x				x		x	o	o	o	x					x		x	x	x	o						o	o
61806	x	x	x	x				x	o	o	o	x					x		o	o	o	o						o	o
61906	x	x	x	x				x	o	o	o	x					x		o	x	x	o						o	o
6006	x	x	x			x		x	o	o	o	x		o			x		o	o	o	o			o			o	

Technical information

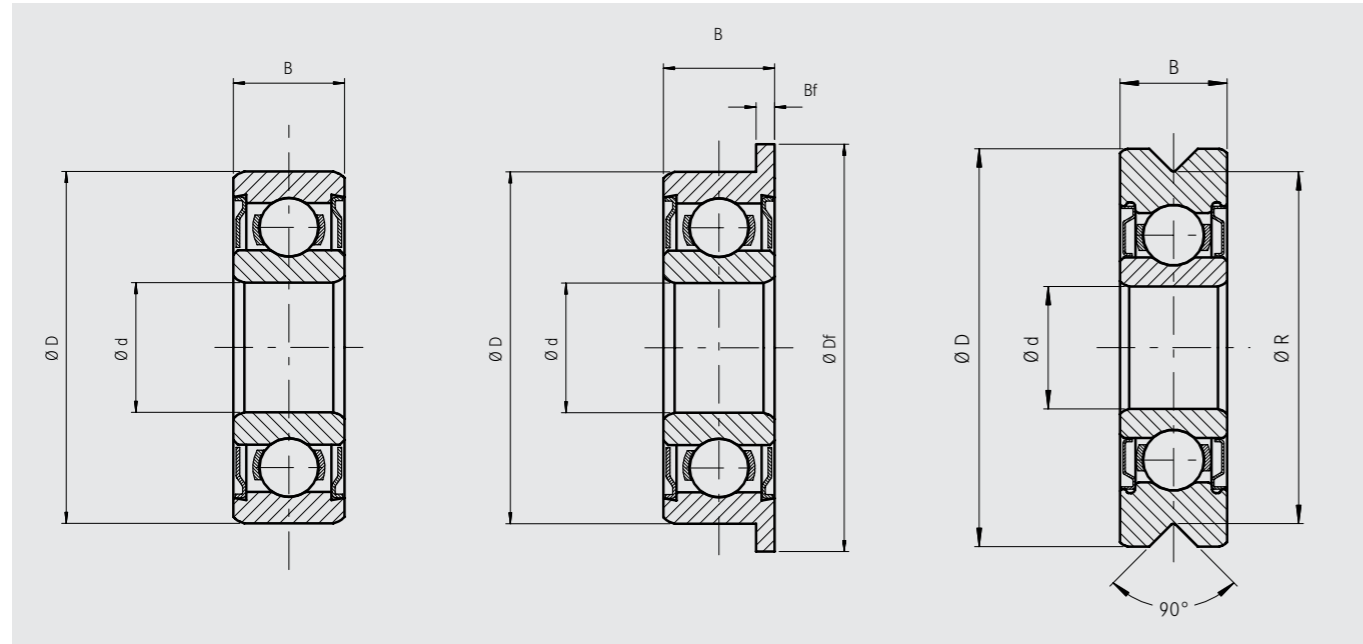

Type	Dimensions in mm							Load ratings in N		Limiting speed			Weight Approx. Gram
	d	D	B	r <sub>s</sub> min	R	D <sub>F</sub>	B <sub>F</sub>	Static C <sub>0r</sub>	Dynamic C <sub>r</sub>	Oil	Grease	2RS	
x 1.000 min <sup>-1</sup>													
623	3	10	4	0,15		11,5	1	220	630	60,0	50,0	26,0	1,65
R623/10	3	10	4	0,15	9,4			220	630	36,0	30,0	15,5	1,50
R623/13	3	13	4	0,15	11			220	630	36,0	30,0	15,5	2,90
618/4	4	9	2,5	0,1		10,3	0,6	225	640	63,0	53,0		0,65
628/4	4	9	3,5	0,1				225	640	63,0	53,0	26,0	1,00
638/4	4	9	4	0,1		10,3	1	225	640	63,0	53,0	26,0	1,35
619/4	4	11	4	0,15		12,5	1	350	965	56,0	48,0	24,0	1,75
604	4	12	4	0,2		13,5	1	350	965	56,0	48,0	24,0	2,34
624	4	13	5	0,2		15	1	490	1.340	48,0	40,0	24,0	3,20
624 TBH	4	13	5	0,2				490	1.340	57,5	48,0	24,0	2,80
R624/13	4	13	5	0,2	12,48			490	1.340	29,0	24,0	14,5	3,10
634	4	16	5	0,3		18	1	680	1.880	60,0	50,0	36,0	5,44
634 TBH	4	16	5	0,3				680	1.880	72,0	60,0	36,0	5,44
R634/16	4	16	5	0,3	15			680	1.880	36,0	30,0	21,5	5,20
618/5	5	11	3	0,15		12,5	0,8	280	715	53,0	45,0		1,16
628/5	5	11	4	0,15		12,6	0,8	280	715	53,0	45,0	25,0	1,62
638/5	5	11	5	0,15		12,5	1	280	715	53,0	45,0	25,0	1,93
619/5	5	13	4	0,2		15	1	430	1.075	50,0	43,0	24,0	2,39
605	5	14	5	0,2		16	1	505	1.330	50,0	40,0	22,0	3,75
625	5	16	5	0,3		18	1	680	1.880	60,0	50,0	36,0	4,90
625 TBH	5	16	5	0,3				680	1.880	72,0	60,0	36,0	4,60
R625/16	5	16	5	0,3	15			680	1.880	36,0	30,0	21,5	5,20
635	5	19	6	0,3		22	1,5	1.050	2.460	48,0	40,0	25,0	9,00
635 TBH	5	19	6	0,3				1.050	2.460	58,0	48,0	25,0	8,70
LR635/21	5	21	6	0,3				1.050	2.460	48,0	40,0	25,0	12,10
R635/21	5	21	6	0,3	19			1.050	2.460	29,0	24,0	15,0	11,30

Technical information

Type	Dimensions in mm							Load ratings in N		Limiting speed			Weight Approx. Gram
	d	D	B	r <sub>s</sub> min	R	D <sub>F</sub>	B <sub>F</sub>	Static C <sub>0r</sub>	Dynamic C <sub>r</sub>	Oil	Grease	2RS	
x 1.000 min <sup>-1</sup>													
618/6	6	13	3,5	0,15		15	1	440	1.080	50,0	40,0		1,87
628/6	6	13	5	0,15		15	1,1	440	1.080	50,0	40,0	22,0	2,68
619/6	6	15	5	0,2		17	1,2	525	1.340	45,0	40,0	22,0	3,85
606	6	17	6	0,3		19	1,2	775	1.795	48,0	40,0	22,0	6,40
606 TBH	6	17	6	0,3				775	1.795	58,0	48,0	22,0	6,40
626	6	19	6	0,3		22	1,5	1.050	2.460	48,0	40,0	25,0	8,60
626 TBH	6	19	6	0,3				1.050	2.460	58,0	48,0	25,0	8,20
LR626/21	6	21	6	0,3				1.050	2.460	48,0	40,0	25,0	11,50
R626/21	6	21	6	0,3	19			1.050	2.460	29,0	24,0	15,0	11,00
618/7	7	14	3,5	0,15		16	1	515	1.175	50,0	40,0		2,03
628/7	7	14	5	0,15		16	1,1	515	1.175	50,0	40,0	22,0	2,95
619/7	7	17	5	0,3		19	1,2	720	1.605	43,0	36,0	20,0	5,26
607	7	19	6	0,3		22	1,5	1.050	2.460	42,0	36,0	25,0	7,90
607 TBH	7	19	6	0,3				1.050	2.460	50,0	43,0	25,0	7,50
627	7	22	7	0,3		25	1,5	1.250	3.200	40,0	33,0	23,0	12,40
627 TBH	7	22	7	0,3				1.250	3.200	48,0	40,0	23,0	12,00
LR627/24	7	24	7	0,3				1.250	3.200	40,0	33,0	23,0	16,40
LR627/26	7	26	7	0,3				1.250	3.200	40,0	33,0	23,0	20,70
R627/26	7	26	7	0,3	23			1.250	3.200	24,0	20,0	14,0	19,10
618/8	8	16	4	0,2		18	1	590	1.250	43,0	36,0		3,11
628/8	8	16	5	0,2		18	1,1	590	1.250	43,0	36,0	20,0	4,05
638/8	8	16	6	0,2		18	1,3	590	1.250	43,0	36,0	20,0	4,70
619/8	8	19	6	0,3		22	1,5	1.050	2.460	42,0	36,0	22,0	7,80
619/8 TBH	8	19	6	0,3				1.050	2.460	50,0	43,0	22,0	7,40
608	8	22	7	0,3		25	1,5	1.250	3.200	41,0	34,0	23,0	12,10
608 TBH	8	22	7	0,3				1.250	3.200	49,0	41,0	23,0	11,30
R608/22	8	22	7	0,3	20,2			1.250	3.200	24,0	20,0	14,0	11,60
LR608/24	8	24	7	0,3				1.250	3.200	41,0	34,0	23,0	15,80
LR608/26	8	26	7	0,3				1.250	3.200	41,0	34,0	23,0	20,20
R608/26	8	26	7	0,3	23			1.250	3.200	24,0	20,0	14,0	17,50
628	8	24	8	0,3				1.400	3.300	34,0	28,0	17,0	18,00
618/9	9	17	4	0,2		19	1	670	1.325	43,0	36,0		3,41
628/9	9	17	5	0,2		19	1,1	670	1.325	43,0	36,0	20,0	4,38
619/9	9	20	6	0,3		23	1,5	1.080	2.465	40,0	34,0	19,0	8,54
609	9	24	7	0,3		27	1,5	1.630	3.650	36,0	30,0	19,0	14,70
609 TBH	9	24	7	0,3				1.630	3.650	43,0	36,0	19,0	13,90
609/d10	10	24	7	0,3				1.630	3.650	36,0	30,0	19,0	14,00
629	9	26	8	0,3				1.970	4.600	33,5	28,0	16,5	19,80
629 TBH	9	26	8	0,3				1.970	4.600	40,0	31,0	16,5	19,00
LR629/28	9	28	8	0,3				1.970	4.600	33,5	28,0	16,5	25,30
LR629/30	9	30	8	0,3				1.970	4.600	33,5	28,0	16,5	31,30
61800	10	19	5	0,3		21	1	840	1.450	43,0	36,0	18,0	5,40
61800 TBH	10	19	5	0,3				840	1.450	51,5	43,0	18,0	5,20
62800	10	19	6	0,3				840	1.450	43,0	36,0	18,0	6,20
63800	10	19	7	0,3		21	1,5	840	1.450	43,0	36,0	18,0	7,40
61900	10	22	6	0,3		25	1,5	1.130	2.550	40,0	34,0	17,3	10,00
61900 TBH	10	22	6	0,3				1.130	2.550	48,0	41,0	17,3	9,70
61900/26	10	26	6	0,3				1.130	2.550	28,0	23,8	17,3	16,80

## Technical information





Type	Dimensions in mm							Load ratings in N		Limiting speed			Weight
	d	D	B	r <sub>s</sub> min	R	D <sub>F</sub>	B <sub>F</sub>	Static C <sub>0r</sub>	Dynamic C <sub>r</sub>	Oil	Grease	2RS	Approx. Gram
										x 1.000 min <sup>-1</sup>			
6000	10	26	8	0,3				1.970	4.600	33,5	28,0	16,5	19,00
6000 TBH	10	26	8	0,3				1.970	4.600	40,0	31,0	16,5	18,40
LR6000/28	10	28	8	0,3				1.970	4.600	33,5	28,0	16,5	24,20
LR6000/30	10	30	8	0,3				1.970	4.600	33,5	28,0	16,5	30,20
R6000/30	10	30	8	0,3	27			1.970	4.600	20,0	17,0	10,0	28,00
16100	10	28	8	0,3				2.370	5.100	30,0	25,0	16,5	23,30
16100 TBH	10	28	8	0,3				2.370	5.100	36,0	30,0	16,5	22,50
6200	10	30	9	0,6				2.600	6.100	32,0	26,0	17,0	29,40
6200 TBH	10	30	9	0,6				2.600	6.100	38,5	31,0	17,0	28,80
LR6200/32	10	32	9	0,6				2.600	6.100	19,0	15,5	10,0	37,50
LR6200/35	10	35	9	0,6				2.600	6.100	19,0	15,5	10,0	47,50
R6200/35	10	35	9	0,6	31			2.600	6.100	19,0	15,5	10,0	43,90
6300	10	35	11	0,6				3.500	8.200	26,0	22,0	13,5	54,50
6300 TBH	10	35	11	0,6				3.500	8.200	31,0	26,5	13,5	53,90
61801	12	21	5	0,3		23	1,1	900	1.930	38,0	32,0	19,0	6,00
61801 TBH	12	21	5	0,3				900	1.930	45,5	38,5	19,0	5,80
62801	12	21	6	0,3				900	1.930	38,0	32,0	19,0	7,10
63801	12	21	7	0,3		23	1,5	900	1.930	38,0	32,0	19,0	8,50
61901	12	24	6	0,3		26,5	1,5	1.450	2.970	36,0	30,0	18,0	10,60
61901 TBH	12	24	6	0,3				1.450	2.970	43,0	36,0	18,0	10,20
6001	12	28	8	0,3				2.370	5.100	30,0	25,0	16,5	21,20
6001 TBH	12	28	8	0,3				2.370	5.100	36,0	30,0	16,5	20,40
16101	12	30	8	0,3				2.370	5.100	30,0	25,0	16,5	27,20
16101 TBH	12	30	8	0,3				2.370	5.100	36,0	30,0	16,5	25,90
6201	12	32	10	0,6				3.100	7.100	27,5	22,5	15,0	36,00
6201 TBH	12	32	10	0,6				3.100	7.100	33,0	27,0	15,0	35,00
LR6201/35	12	35	10	0,6				3.100	7.100	27,5	22,5	15,0	47,00
6301	12	37	12	1				4.200	9.700	25,0	21,0	14,0	62,00
6301 TBH	12	37	12	1				4.200	9.700	30,0	25,0	14,0	59,00
61802	15	24	5	0,3		26	1,1	1.100	2.080	34,0	28,0	16,0	7,20
61802 TBH	15	24	5	0,3				1.100	2.080	41,0	33,5	16,0	6,90
62802	15	24	6	0,3				1.100	2.080	34,0	28,0	16,0	8,30
63802	15	24	7	0,3		26	1,5	1.100	2.080	33,0	28,0	16,0	10,00
61902	15	28	7	0,3		30,5	1,5	2.260	4.350	30,0	24,0	13,5	17,80
61902 TBH	15	28	7	0,3				2.260	4.350	36,0	29,0	13,5	17,30
16002	15	32	8	0,3				2.850	5.600	26,0	23,0	13,5	26,90
16002 TBH	15	32	8	0,3				2.850	5.600	31,0	27,5	13,5	25,70
6002	15	32	9	0,3				2.850	5.600	26,0	23,0	13,5	29,20
6002 TBH	15	32	9	0,3				2.850	5.600	31,0	27,5	13,5	28,40
6202	15	35	11	0,6				3.500	7.700	24,0	20,0	13,0	44,80
6202 TBH	15	35	11	0,6				3.500	7.700	29,0	24,0	13,0	43,80
LR6202/40	15	40	11	0,6				3.500	7.700	24,0	20,0	13,0	70,00
LR6202/47	15	47	11	0,6				3.500	7.700	24,0	20,0	13,0	110,60
R6202/47	15	47	11	0,6	41			3.500	7.700	14,5	12,0	8,0	100,30
6302	15	42	13	1				5.400	11.400	23,0	18,0	10,3	84,00
6302 TBH	15	42	13	1				5.400	11.400	27,5	21,5	10,3	82,00

## Technical information

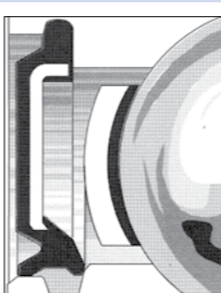

Type	Dimensions in mm							Load ratings in N		Limiting speed			Weight
	d	D	B	r <sub>s</sub> min	R	D <sub>F</sub>	B <sub>F</sub>	Static C <sub>0r</sub>	Dynamic C <sub>r</sub>	Oil	Grease	2RS	Approx. Gram
										x 1.000 min <sup>-1</sup>			
61803	17	26	5	0,3		28	1,1	1.270	2.240	30,0	24,0	15,0	7,30
62803	17	26	6	0,3				1.270	2.240	30,0	24,0	15,0	9,20
63803	17	26	7	0,3		28	1,5	1.270	2.240	30,0	24,0	15,0	11,00
61903	17	30	7	0,3		32,5	1,5	2.550	4.600	28,0	22,0	14,0	16,50
61903 TBH	17	30	7	0,3				2.550	4.600	33,5	26,5	14,0	16,10
16003	17	35	8	0,3				3.250	6.000	23,0	19,0	13,0	32,50
16003 TBH	17	35	8	0,3				3.250	6.000	27,5	23,0	13,0	30,40
6003	17	35	10	0,3				3.250	6.000	23,0	19,0	13,0	38,80
6003 TBH	17	35	10	0,3				3.250	6.000	27,5	23,0	13,0	37,70
6203	17	40	12	0,6				4.750	9.800	21,0	17,5	12,0	65,00
6203 TBH	17	40	12	0,6				4.750	9.800	25,0	21,0	12,0	63,00
6303	17	47	14	1				6.600	13.000	19,0	16,0	11,0	115,00
61804	20	32	7	0,3		35	1,5	2.300	3.900	24,0	19,0	11,5	18,00
61904	20	37	9	0,3		40	2	3.700	6.300	22,0	18,0	11,5	40,00
6004	20	42	12	0,6				5.000	9.300	20,0	17,0	11,0	66,50
6004 TBH	20	42	12	0,6				5.000	9.300	24,0	20,5	11,0	65,80
6204	20	47	14	1				6.550	12.700	18,0	15,0	9,3	103,50
6204 TBH	20	47	14	1				6.550	12.700	21,5	18,0	9,3	102,00
6304	20	52	15	1,1				7.900	15.900	17,0	14,0	8,8	144,00
61805	25	37	7	0,3		40	1,5	2.600	4.150	20,0	17,0	9,8	24,00
61905	25	42	9	0,3		45	2	4.350	6.900	19,0	16,0	9,8	47,00
6005	25	47	12	0,6				5.850	10.000	18,0	15,0	9,7	78,00
6005 TBH	25	47	12	0,6				5.850	10.000	21,5	18,0	9,7	76,50
6205	25	52	15	1				7.800	14.000	17,0	14,0	8,0	125,00
6205 TBH	25	52	15	1				7.800	14.000	20,5	17,0	8,0	125,00
6305	25	62	17	1,1				10.900	21.200	14,0	12,0	7,5	230,00
61806	30	42	7	0,3		45	1,5	2.900	4.300	18,0	15,0	8,4	27,00
61906	30	47	9	0,3		50	2	4.600	7.000	17,0	14,0	8,1	53,00
6006	30	55	13	1				8.300	13.200	16,0	13,0	8,0	120,00
6206	30	62	16	1				11.300	19.500	14,0	11,0	6,7	200,00
6206 TBH	30	62	16	1				11.300	19.500	17,0	13,0	6,7	200,00
6306	30	72	19	1,1				15.000	26.700	12,0	10,0	6,3	360,00

Type	Dimensions in mm							Load ratings in N		Limiting speed			Weight
	d	D	B	r <sub>s</sub> min	R	D <sub>F</sub>	B <sub>F</sub>	Static C <sub>0r</sub>	Dynamic C <sub>r</sub>	Oil	Grease	2RS	Approx. Gram
										x 1.000 min <sup>-1</sup>			
R4	1/4	6,350	5/8	15,875	3/16	4,978	0,3	620	1.480	45,0	38,0		4,50
R4A	1/4	6,350	3/4	19,050	7/32	5,558	0,3	900	2.340	43,0	36,0		7,50
R4A-2Z	1/4	6,350	3/4	19,050	9/32	7,142	0,3	900	2.340	43,0	36,0	20,0	10,00
R6	3/8	9,525	7/8	22,225	7/32	5,556	0,3	1.420	3.330	38,0	32,0		9,00
R6-2Z	3/8	9,525	7/8	22,225	9/32	7,142	0,3	1.420	3.330	38,0	32,0	17,5	12,00
R8	1/2	12,700	1 1/8	28,575	1/4	6,350	0,3	2.410	5.100	32,0	27,0		11,50
R8-2Z	1/2	12,700	1 1/8	28,575	5/16	7,938	0,3	2.410	5.100	32,0	27,0	15,0	24,00
R10	5/8	15,875	1 3/8	34,925	9/32	7,142	0,3	3.280	6.000	25,0	21,0		23,50
R10-2Z	5/8	15,875	1 3/8	34,925	11/32	8,733	0,3	3.280	6.000	25,0	21,0	11,5	38,00

### Versions of cages and seals

Version	Abbreviation	Description	Properties	Design
Shields and seals	Z	Non-contact sheet steel shield	Protection against rough pollution and loss of grease	
	RZ	Steel armoured NBR-seal, non-contact	Additional protection against loss of grease with outer ring rotation	
	RU	Steel armoured non-contact seal	Proper sealing effect without speed limitation	
	RS	Steel armoured NBR contact seal	Superior sealing effect, please attend speed limitation	
	VS	Steel armoured high temperature contact seal	Like RS, but higher temperature stability	
	BRS	Steel armoured NBR non-contact seal, optimized labyrinth	Balanced sealing effect without speed limitation	
	URS	Steel armoured NBR contact seal, 2 sealing lips	Best sealing effect, please attend speed limitation	

### Versions of cages and seals

Version	Abbreviation	Description	Properties	Design
Cages	J	Sheet steel, two-part clamped or riveted	Standard cage, high volume of grease, high temperature stability	
	Y	Sheet brass, two-part clamped	Non-magnetizable, grease compatibility must be tested	
	T9H	Crown cage, made from PA66GF	For highest speed, please pay attention to temperatures and bearing position	
	TXH	Crown cage, made from PEEKGF	For highest speed and high temperature, please pay attention to bearing position	
	TBH	Crown cage, fibre reinforced, machined	For highest speed, emergency running properties, please pay attention to temperatures and bearing position	
	Radial Play	C1	Radial clearance according to Zwicker factory standards, smaller than C2	
C2		Radial clearance according to DIN620T4, smaller than CN	See page 16	
CN		Standard radial clearance according to DIN620T4	See page 16	
C3		Radial clearance according to DIN620T4, larger than CN	See page 16	
C4		Radial clearance according to DIN620T4, larger than C3	See page 16	
C5		Radial clearance according to Zwicker - factory standards, larger than C4		
Accuracy	PN	Standard accuracy according to DIN620T2		
	P6	Accuracy according to DIN620T2, better than PN		
	P5	Accuracy according to DIN620T2, better than P6		
	P4	Accuracy according to DIN620T2, better than P5		
	P2	Accuracy according to DIN620T2, better than P4		
Adjustment	G1, G2, G3	Matched bearings	See page 20 and 21	

## Internal bearing clearance, factors of rotational speed, fittings

### Radial clearance

Most applications can be covered with the standard internal bearing clearance. There are though a number of special cases in which a lower or higher internal bearing clearance is needed. Our office for technical application will be glad to help you determining the optimal clearance range. Following up an extract from the DIN620T4:

Bore diameter (mm)		Radial clearance (µm)									
		C2		CN		C3		C4		C5*	
über	bis	min.	max.	min.	max.	min.	max.	min.	max.	min.	max.
1,5	6	0	7	2	13	8	23	-	-	-	-
6	10	0	7	2	13	8	23	14	29	20	37
10	18	0	9	3	18	11	25	18	33	25	45
18	24	0	10	5	20	13	28	20	36	28	48
24	30	1	11	5	20	13	28	23	41	30	53

\* internal bearing clearance C5 according to factory standard

### Bearing fits

Ball bearing rings need to be well supported by shaft and housing. The general rule in this case is that the ring carrying the rotating load gets the tight fit. Following up the standard values for fits of shafts and housings:

Selection of shaft tolerances for solid steel shafts			
Rotational condition	Example	Installation of the inner ring	ISO-field of tolerance
Point load on inner ring	Fans, wheel bearings	Inner ring axially movable Inner ring tight fit	g5 (g6)* j5, js5 (j6)*
Circumference load on inner ring	Milling, grinding	Inner ring tight fit	j5, js5 (j6)*

Selection of housing tolerances for steel or cast iron housings			
Rotational condition	Example	Installation of the inner ring	ISO-field of tolerance
Point load on outer ring	Milling, grinding	Outer ring axially movable Outer ring tight fit	H6 (H7)* J6
Circumference load on outer ring	Fans, wheel bearings	Outer ring tight fit	K6 (M6, N6)*

\* values for heavy operating conditions.

### Limiting speeds

The limiting speeds mentioned in the chart below apply to the mentioned bearing design in basic precision and radial clearance class with balanced thermal budget and axial positioning. For the determination of the limiting speeds for special designs the following applies:

$$n_{max} = n_g \times f_{n1} \times f_{n2} \times f_{n3} \times f_{n4} \times f_{n5} \times f_{n6}$$

Factors of rotational speed			Further information
Ball material $f_{n1}$	Chrome steel Ceramics	1,0 1,25	Si <sub>3</sub> N <sub>4</sub>
Cages $f_{n2}$	J/Y TBH* T9H	1,0 1,2 1,6	n x dm < 625.000 mm/min n x dm < 1.000.000 mm/min n x dm < 1.400.000 mm/min
Kinematics $f_{n3}$	„Inner ring rotates Outer ring rotates“	1,0 0,6	
Accuracy $f_{n4}$	PN, P6, P5, P4	1,0 1,2 1,4	
Positioning of bearings $f_{n5}$	Single bearing, not preloaded	0,5	
	Single bearing, spring preloaded	1,0	
	Matched bearings acc. to G1, G2	0,8	
	Matched bearings acc. to G1, G2, with axial clearance	0,7	
	Matched bearings acc. to G3, spring preloaded	1,0	
Cover $f_{n6}$	Open-type, BRS, RU, RZ, Z	1,0	
	RS, URS, VS	0,8	

\* for technical data, the higher limiting speeds for TBH bearings have already been minded.

## Tolerances of corresponding parts

Ball bearings only reach their load carrying capacity if the rings are well supported by the corresponding parts. A consequence of this support is that any form deviation of the bearing seats will be represented on the raceways. The squareness and evenness of the abutment surfaces, locknuts and screw covers also have a strong influence on the performance of the ball bearings. The following charts show recommendations for machining tolerances of shaft and housing. The thinner the wall thickness of the rings (series 617 ..., 618 ..., 619 ...), the more important becomes the precision of the corresponding parts.

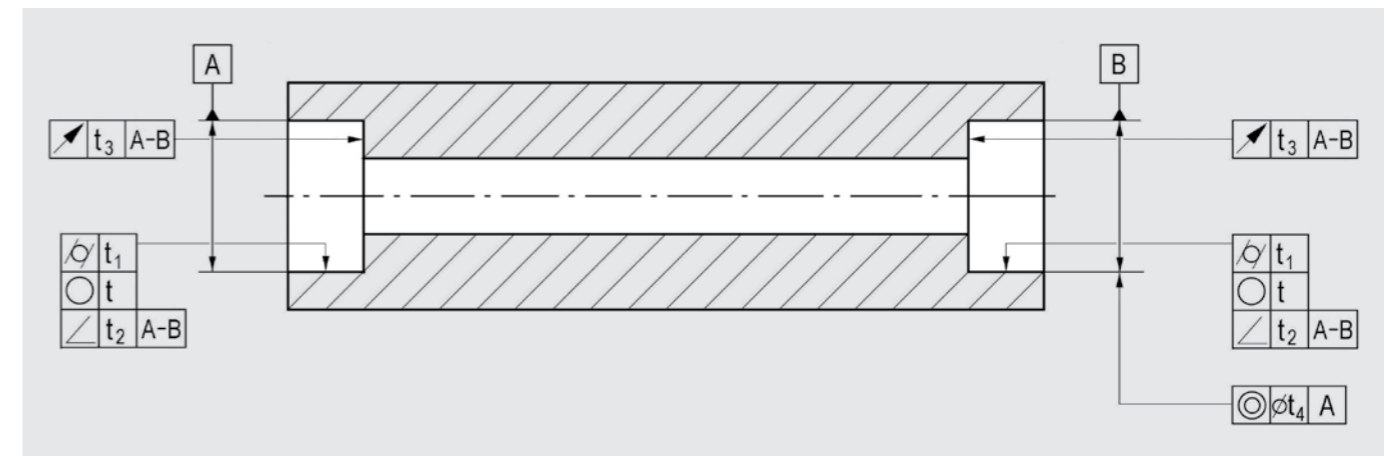
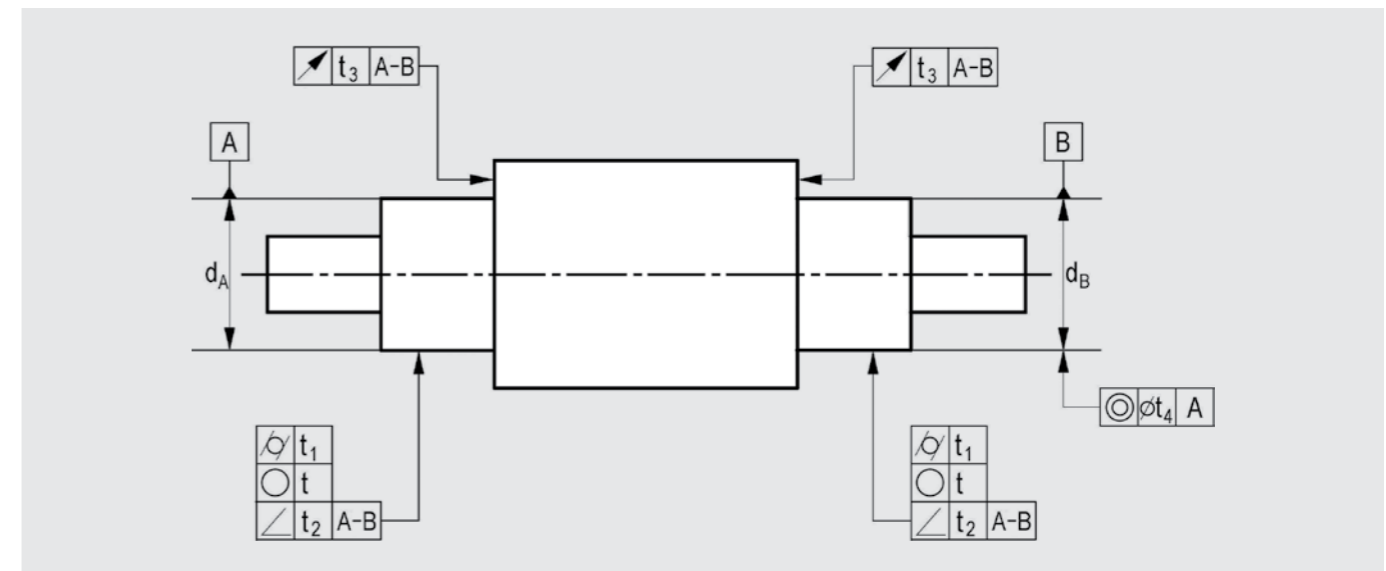

Property	Symbol	Tolerance value	Allowed shape deviation for tolerance class			
			PN	P6	P5	P4
Roundness	○	t	IT5/2	IT4/2	IT3/2	IT1
Tapering	⊗	t <sub>1</sub>	IT5/2	IT3	IT2	IT1
Squareness	∟	t <sub>2</sub>	IT5/2	IT3	IT2	IT1
Axial runout	↗	t <sub>3</sub>	IT5/2	IT3	IT2	IT1
Concentricity	◎	t <sub>4</sub>	IT4	IT4	IT3	IT3

Nominal diameter (mm)		Tolerance quality (µm)				
over	up to	IT1	IT2	IT3	IT4	IT5
1	3	0,8	1,2	2	3	4
3	6	1	1,5	2,5	4	5
6	10	1	1,5	2,5	4	6
10	18	1,2	2	3	5	8
18	30	1,5	2,5	4	6	9
30	50	1,5	2,5	4	7	11
50	80	2	3	5	8	13

## Lubrication

The purpose of lubrication is to separate the surfaces of the bearing components as good as possible and thereby provide low friction and inhibit wearing.

If not specified differently, shielded and/or sealed Zwicker ball bearings are delivered for-life-lubricated with a high class lithium based grease. Open-type bearings are provided either with a corrosion protective on the basis of mineral oil or with a specified lubricant upon request.

## Oil lubrication

Oil lubrication is mainly used if

- the aggregate already has an oil lubrication and the bearing is to be supplied as well
- heat is to be dissipated
- highest cleanliness in the lubricating gap is necessary
- high demands on a low torque do not permit a grease or solid lubrication

Our application engineering provides support for a proper oil selection. The required amount of lubrication may be determined either by tests or on recommendation of the lubricant supplier.

Following up an excerpt from the program of lubricating oils with which Zwicker ball bearings can be delivered.

### Ball bearing oils

Labeling	Producer	Oil basis	Pour point	Flashpoint	Kinematic viscosity at 40 °C	Properties	Application area
Aeroshell Fluid 12	Shell	Synthetic	< -60°	~ 220°C	15 mm <sup>2</sup> /s	Low vaporization rate, MIL-L-6085 C	Instruments, turbines, spindles, gyroscopes
Ensis Öl N	Shell	Mineral oil	-12°	~ 200°C	68 mm <sup>2</sup> /s	Adherent, well compatible with lubricants and plastics	Standard corrosion protection for Zwicker ball bearings
Isoflex PDP38	Klüber	Ester oil, synthetic	-70°	~ 200°C	12 mm <sup>2</sup> /s	Able to work under high pressure, protects from corrosion	Spindles, high-precision instruments, ball bearings
Tonna T 68	Shell	Mineral oil	-15°	~ 225°C	68 mm <sup>2</sup> /s	Inhibits slipstik-effects, well adherent, aging stable	Guide bars, guides, ball bearings

## Grease lubrication

The majority of deep groove ball bearings used worldwide is for-life lubricated with grease. This means that the bearing service life is reached at latest with the end of the grease's period of use. The for-life grease lubrication is used if

- A maintenance-free handling of the bearing application is important
- Equipment for later re-lubrication is not available due to space or application reasons
- No heat dissipation via the lubricant is necessary
- The product of the target speed and the bearing's pitch circle diameter ( $n \times d_m$ ) is smaller than the speed factor of the available greases

To achieve a running friction that is as low as possible and a long service life at high speeds, it is necessary to perform a grease distributing run. This helps to lower the primarily occurring heightened friction by splashing and can positively influence the service life as well as the speed capability.

Following up some of the mostly used greases for Zwicker ball bearings:

### Ball bearing greases

Labeling	Producer	Oil basis	Thickener	Temperature range	NLGI-class	Rotation speed factor $n \times d_m$	Properties	Application area
Asonic GLY32	Klüber	Synth. HC-oil/ester oil	Lithium	-50 °C bis +140 °C	2	1.000.000	For extremely low noise bearings	Office machines, textile machines
Asonic GHY72	Klüber	Ester oil	Polyurea	-40 °C bis +180 °C	2/3	600.000	For extremely low noise bearings and high temperatures	Home appliances, fan motors
Barrierta L55/2	Klüber	Fluorinated polyether oil	PTFE	-40 °C bis +260 °C	2	300.000	High temperature grease, water- and solvent-resistant	Electric motors ISO-class F, pulleys
Isoflex LDS18 Spezial A	Klüber	Mineral oil/ester oil	Lithium	-50 °C bis +120 °C	2	1.000.000	High speed grease, fine pressure capability	Precision mechanics, optics, low temperatures, standard Zwicker grease
Isoflex Topas NB52	Klüber	Polyalpha-olefin	Barium-complex	-50 °C bis +150 °C	2	1.000.000	Distinct effect of wear protection, fine corrosion protection, water-resistant	Very high rotation speeds, high and low temperatures
Klüberquiet BQH 72-102	Klüber	Ester oil	Polyurea	-40 °C bis +180 °C	2/3	700.000	For low noise bearings and high temperatures	Electric motors, generators, belt tensioners
Klüber speed BF 72-22	Klüber	Synthetic	Polyurea	-50 °C bis +120 °C	2/3	2.000.000	High speed grease, very water-resistant	High speed spindles, electric motors
Staburags NBU 8EP	Klüber	Mineral oil	Barium-komplex	-20 °C bis +140 °C	2	500.000	Resists heavy splash water and vapor influence, high rotation speed	High radial load, also shock load
Krytox GPL 227	Du Pont	Fluorinated polyether oil	PTFE	-20 °C bis +288 °C	2	~200.000	High temperatures, corrosion protection	Furnace bearings, guides, laminate presses
Longtime PD2	BP	Mineral oil	Lithium	-35 °C bis +140 °C	2	1.000.000	Inhibits Slipstik-effect, EP-additives	Speed sensors
Thermoplex 2 TML	Lubcon	Synthetic	Lithium	-35 °C bis +170 °C	2	1.300.000	High speed and high temperature grease	Textile industry, small and miniature bearings
Turmotemp Super 2EP	Lubcon	Synthetic	MeK	-30 °C bis +280 °C	2	300.000	No special purification required, very high metal affinity	Pulleys in ovens, electric motors ISO-class F
Turmsilon-greasmittel TF	Lubcon	Silicone	Polyurea	-40 °C bis +230 °C	2	200.000	For moderate load, wide temperature range	Home appliances, conveyors, plastic parts

Of course we lubricate the bearings with any desired grease.

## Matched bearings

For a multitude of applications the load carrying capacity of a single bearing is not sufficient. Therefore two or more bearings need to be combined as multiple arrangements. To obtain a balanced load distribution the bearings have to be matched.

The matching method depends on the assembling possibilities and applied loads. The nomenclature of the matching versions results from the positive direction of the clearance interactions. The matching versions are

### Face-to-face arrangement (G1)

- The face-to-face arrangement is chosen if
  - Axial loads in both directions need to be supported
  - Clamping of the bearings against each other is only possible for the outer rings
  - Relatively high angular misalignment is expected
  - Tilting moment rigidity is secondary

### Back-to-back arrangement (G2)

- The back-to-back arrangement is chosen if
  - Axial loads in both directions need to be supported
  - Clamping of the bearings against each other is only possible for the inner rings
  - The accuracy of the corresponding parts is high
  - A tilting moment rigidity as high as possible is demanded

### Tandem-arrangement (G3)

- The tandem-arrangement is chosen if
  - High axial loads in one direction need to be supported
  - Preloading of the bearings with an aligned bearing or by springs is possible
  - High speeds are expected

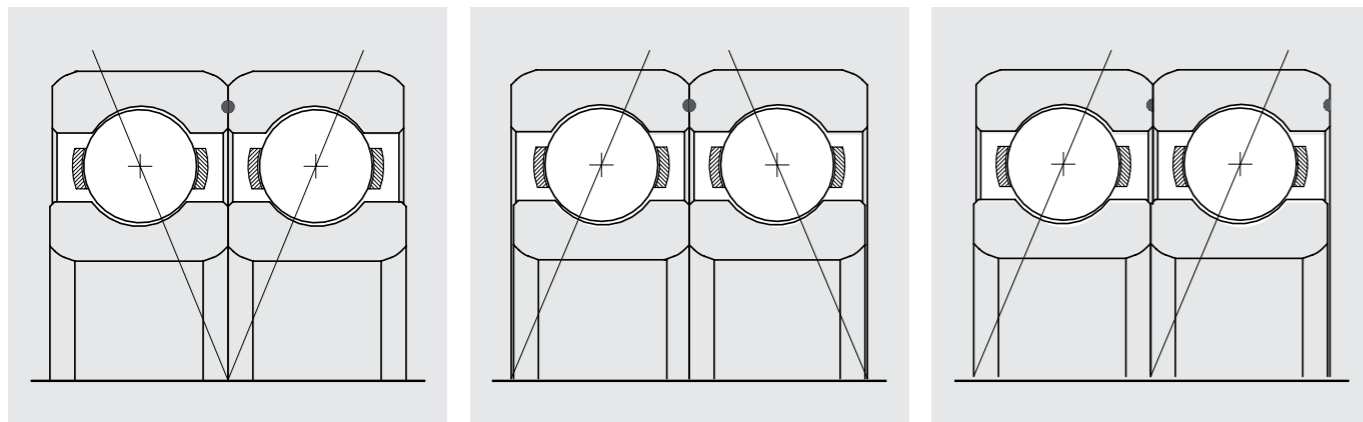

Matched bearings are usually matched with a defined preload. A specified axial clearance (GUA) or universal matching (GU) is possible for G1- and G2- bearing sets on request.

## Matched bearings

### Preloads

Bearing arrangements are matched with a defined preload by default.

Type series	Axial measuring load			
	10N	20N	30N	40N
618 ...	up to 17 mm	20 to 35 mm	from 40 mm	–
619 ...	up to 10 mm	12 to 25 mm	30 to 50 mm	from 55 mm
60 ...	up to 7 mm	8 to 15 mm	17 to 30 mm	from 35 mm
62 ...	up to 7 mm	8 to 15 mm	17 to 30 mm	from 35 mm

The preload values depend not only on the size of the bearing but also on the boundary conditions of the application. Therefore special preload values can be specified on request.

### Design specifics

For the design of a bearing pair for an application some specifics need to be considered. As the running properties of both bearings influence each other, matched bearings should at least be produced in precision class ISO 5 (P5 or ABEC5).

The width tolerance of matched single bearings and/or bearing pairs is higher than standard. The DIN620 provides the following values:

Bore diameter d (mm)	Width tolerance (µm)		
	Single bearing	Matched single bearing	Bearing pairs
up to 10 mm	0-40	0-250	0-500
over 10 to 18 mm	0-80	0-250	0-500
over 18 to 50 mm	0-120	0-250	0-500

Therefore it is important to consider when changing a bearing that the clamping elements can always exert enough axial pressure on the rings to be clamped. It is recommended to hint to this in maintenance plans and instructions and to arrange a length adaptation by precision washers.

The limiting speeds for bearing pairs matched according to G1 and G2 are lower than those of single spring preloaded bearings.

$$n_{g\ G1, G2} = 0,8\ n_{gi}$$

Shielded or sealed bearing pairs are equipped with shields or seals on the outside of the bearing pair only while the inner faces remain open. In case that double shielded/sealed bearings are required – due to wide bearing interspaces or vertical axis application – this is to be separately stated on the order.



*A strong network: Künemund Group's manufacturing and trading companies are situated in various locations across Germany.*

- 1 ADITEC GmbH, 72829 Engstingen-Haid
- 2 Compound GmbH Hochtemperatur Wälzlager, 77694 Kehl am Rhein
- 3 Künemund Wälzlager Halle GmbH, 06179 Teutschenthal-Holleben
- 4 Künemund GmbH, 77694 Kehl am Rhein
- 5 Künemund GmbH & Co. KG, 70565 Stuttgart
- 6 Künemund Dichtungstechnik GmbH, 47918 Tönisvorst
- 7 RZ Horlacher GmbH, 70565 Stuttgart
- 8 Ritter Lineartechnik GmbH, 77767 Appenweier-Urloffen
- 9 Sauer Kugellager GmbH, 90475 Nürnberg
- 10 Zwicker Kugellager GmbH, 94508 Schöllnach

*Zwicker Kugellager GmbH is a Künemund Group company. This strong alliance of consolidated companies unites professionals specialising in consultancy and sales with skilled experts in the production of roller bearings, seals and linear technology.*

**Further added value**

- **Group know-how:**  
there is a constant exchange of knowledge taking place within the Group. This ensures that we are familiar with all products across the board and that our know-how is completely up to date.
- **Commercial competence:**  
at each of our five trading enterprises you have access to the entire range of products supplied by the Künemund Group – roller bearings, seals and linear technology.
- **Flexible sales:**  
our professional field staff will be happy to visit you to offer advice.
- **Fast order processing:**  
five distribution centres and our own production facilities ensure high levels of product availability.
- **Full-range supplier:**  
we supply products from top manufacturers such as GMN, GRW, Koyo, Schaeffler, Timken etc.
- **Merchandise management competence:**  
RZ Horlacher GmbH takes care of reliable provision of all IT solutions within the Künemund Group.

**We not only supply you with products, but also solutions. Because we are not just distributors but also manufacturers.**

Dr Kai Dürr, Managing Director, Künemund GmbH & Co. KG



## Your contact to our trading enterprises (for consultation and orders)

### ADITEC GmbH

Dietrich-Bonhoeffer-Straße 8  
72829 Engstingen-Haid  
Phone +49 7129 936759-0  
Fax +49 7129 936759-20  
info@aditec-technologie.de

### Künemund Wälzlager Halle GmbH

An der Schnellbahn 2  
06179 Teutschenthal-Holleben  
Phone +49 345 444-6666  
Fax +49 345 444-1159  
info@kuenemund.de

### Künemund GmbH

Max-Planck-Straße 6  
77694 Kehl am Rhein  
Phone +49 7851 8702-0  
Fax +49 7851 73382  
info@kuenemund.com

### Künemund GmbH & Co. KG

Schockenriedstraße 46 A  
70565 Stuttgart  
Phone +49 711 72587-0  
Fax +49 711 72587-50  
vertrieb@kuenemund.net

### Sauer Kugellager GmbH

Am Flachmoor 8  
90475 Nürnberg  
Phone +49 9128 91181-0  
Fax +49 9128 91181-32  
info@sauer-kugellager.de

## Other manufacturing enterprises within the Künemund Group

### ADITEC GmbH

Dietrich-Bonhoeffer-Straße 8  
72829 Engstingen-Haid

### Compound GmbH Hochtemperatur Wälzlager

Max-Planck-Straße 6  
77694 Kehl am Rhein

### Künemund Dichtungstechnik GmbH

Lenenweg 8  
47918 Tönisvorst

### Ritter Lineartechnik GmbH

Im Ettenbach 5  
77767 Appenweier-Urloffen



## Zwicker Kugellager GmbH

Emminger Straße 3 | 94508 Schöllnach  
Phone +49 9903 9309-0 | Fax +49 9903 9309-33  
info@zwicker-kugellager.de

[www.zwicker-kugellager.de](http://www.zwicker-kugellager.de)



**ZWICKER**  
**PRECISION BEARINGS**  
Teamwork guarantees performance!