

CATALOGUE NO. 985

SECTION C

# **R B L SPLIT HOUSING PILLOW BLOCKS**

**CAST IRON — DUCTILE IRON — CAST STEEL**

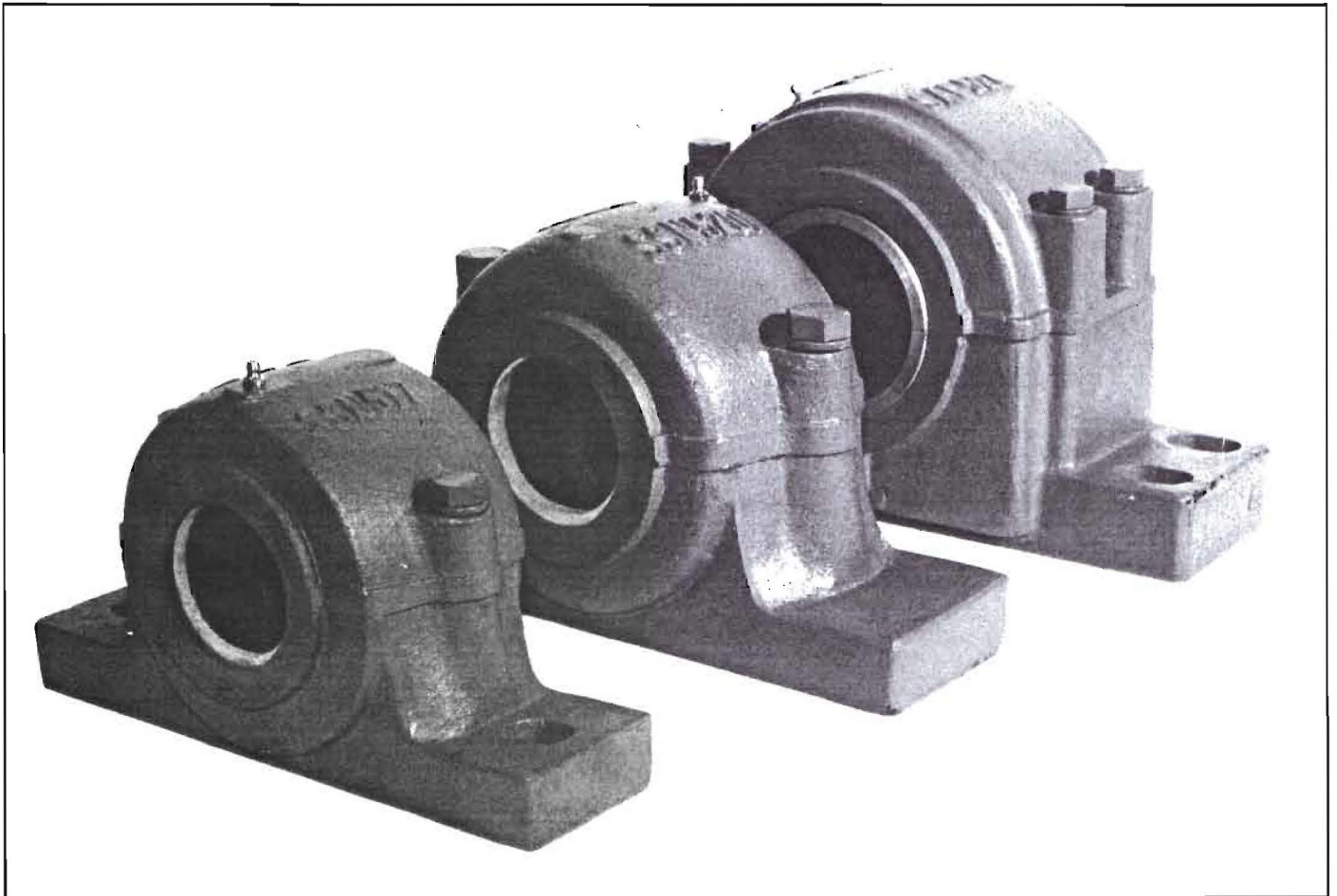

**ringball bearings ltd.**

**MONTREAL**  
80 Hymus Boulevard  
Pointe Claire, P.Q.  
H9R 1E3  
(514) 695-0460  
TELEX: 05-821633

**TORONTO**  
245 Dalesford Rd.  
Toronto, Ont.  
M8Y 1G4  
(416) 255-5547  
TELEX: 06-967748

**WINNIPEG**  
884 Bradford St.  
Winnipeg, Man.  
R3H 0N5  
(204) 775-8521  
TELEX: 07-57698

**EDMONTON**  
8220 Davies Rd.  
Edmonton, Alta.  
T6E 4N2  
(403) 465-3311  
TELEX: 037-2326

**VANCOUVER**  
2131 Willingdon Ave.  
Burnaby, B.C.  
V5C 5J4  
(604) 294-3461  
TELEX: 04-354754



# SPLIT HOUSING PILLOW BLOCKS

## I N D E X

ITEM	PAGE
Description — Types & Characteristics ...	2 - 3
Series <b>SN 1500-S</b> .... Cast Iron .....	4 - 5
Series <b>SN 1600-S</b> .... Cast Iron .....	4 - 5
Series <b>SN 22500-S</b> ... Cast Iron .....	6 - 7
Series <b>SN 22600-S</b> ... Cast Iron .....	8 - 9
Series <b>SSN 1500</b> .....	Cast Iron .....
Series <b>SSN 22500</b> .....	Cast Iron .....
Series <b>SSN 1500-D</b> ... Ductile Iron ....	10 - 11
Series <b>SSN 22500-D</b> .. Ductile Iron ....	12 - 13
Series <b>SAF 1500</b> .....	Cast Iron .....
Series <b>SAF 1600</b> .....	Cast Iron .....
Series <b>SAF 22500</b> .... Cast Iron .....	14 - 15
Series <b>SAF 22600</b> .... Cast Iron .....	16 - 17
Series <b>SAF 22600</b> .... Cast Iron .....	18 - 19
Assembly Instructions .....	20 - 21
Load Rating Tables .....	22 - 23
Lubrication Instructions .....	24 - 25
Mounting Clearances .....	26
Cleaning Information .....	27
Shaft Tolerance Limits .....	27
Material Specifications .....	27
New Fixing Ring Dimensions .....	28

# ringball bearings Ltd.

**Material:  
Cast Iron or  
Ductile Iron**

**Available with  
End Covers**

**Different Sized Dowels  
to Prevent Reversal  
of Cap**

**Felt Seals**

**Solid Base**

**Angled construction  
for extra strength**

**Suitable for Double  
Row Ball or Spherical  
Roller Bearings either  
fixed or floating**

**All basic dimensions  
interchangeable  
with other makes**

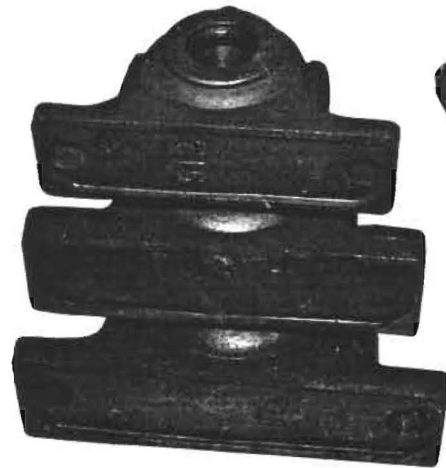

**NEW Solid Foot Design  
for Additional Strength**



**Old  
Hollow  
Design**



ringball bearings ltd.

**R B L SPLIT HOUSING PILLOW BLOCKS**

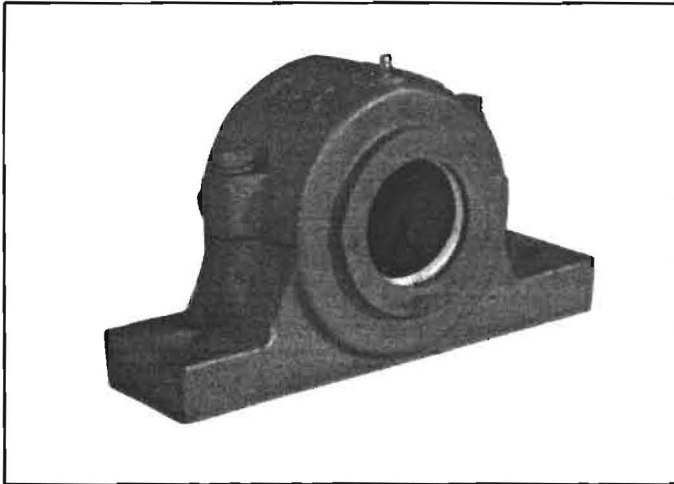

**Type SN-500-S  
Type SN-600-S  
2-bolt, Solid Base, Cast Iron**

Page 4 - 9



**Type SSN-500  
Solid Base, Cast Iron  
for 2 or 4-bolt drilling**

Page 10 - 11



**Type SSN-500-D Ductile  
Solid Base, Ductile Iron  
for 2 or 4-bolt drilling**

Page 12 - 13

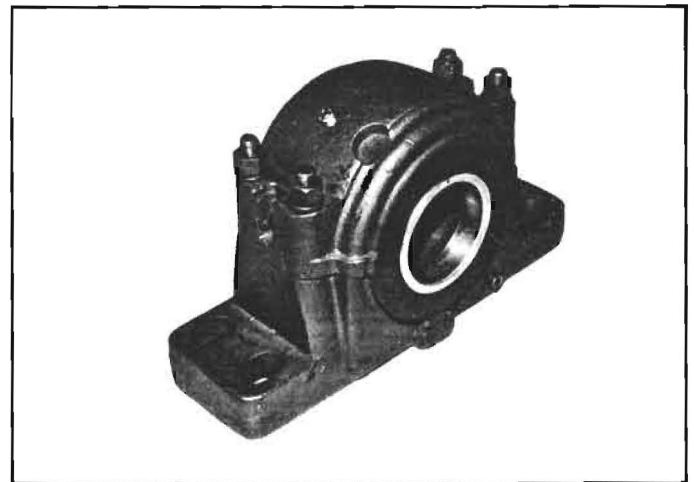

**Type SAF-500  
Type SAF-600  
Cast Iron or Cast Steel**

Page 14 - 15

# ringball bearings Ltd.

**RBL** SPLIT HOUSING PILLOW BLOCKS  
for self-aligning ball bearings  
with adapter sleeves

SERIES **SN 1500-S**

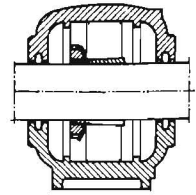
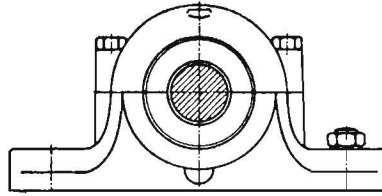

**SOLID BASE - CAST IRON - 2 BOLT HOLES**

Standard Shaft dia. inch	Complete Pillow Block number	COMPONENT PART NUMBERS						Alternate Shaft Sizes					
		Housing number	Bearing		Adapter sleeve number	Fixing rings (No. req'd.)		dia. inch	Adapter number	dia. inch	Adapter number	dia. mm	Adapter number
			Bearing number	Dyn. Load Rtg. Lbs.									
3/4	SN 1505-S-3/4	SN 505-S	1205-K	2090	HE 205	2	52/5					20	H 205
15/16	SN 1506-S-15/16	SN 506-S	1206-K	2700	HA 206	2	62/7	1	HE 206	7/8	HS 206	25	H 206
13/16	SN 1507-S-13/16	SN 507-S	1207-K	2700	HA 207	2	72/8			1 1/8	HS 207	30	H 207
15/16	SN 1508-S-15/16	SN 508-S	1208-K	3300	HA 208	2	80/7.5	1 1/4	HE 208	1 3/8	HS 208	35	H 208
17/16	SN 1509-S-17/16	SN 509-S	1209-K	3800	HA 209	2	85/6	1 1/2	HE 209			40	H 209
1 1/16	SN 1510-S-1 1/16	SN 510-S	1210-K	3900	HA 210	2	90/6.5	1 3/4	HE 210	1 5/8	HS 210	45	H 210
1 1/8	SN 1511-S-1 1/8	SN 511-S	1211-K	4600	HA 211	2	100/6	2	HE 211	1 7/8	HS 211	50	H 211
2 1/16	SN 1512-S-2 1/16	SN 512-S	1212-K	5200	HA 212	2	110/8			2 1/8	HS 212	55	H 212
2 3/16	SN 1513-S-2 3/16	SN 513-S	1213-K	5300	HA 213	2	120/10	2 1/4	HE 213	2 3/8	HS 213	60	H 213
2 7/16	SN 1515-S-2 7/16	SN 515-S	1215-K	6700	HA 215	2	130/8	2 1/2	HE 215			65	H 215
2 11/16	SN 1516-S-2 11/16	SN 516-S	1216-K	6800	HA 216	2	140/8.5	2 3/4	HE 216			70	H 216
2 15/16	SN 1517-S-2 15/16	SN 517-S	1217-K	8400	HA 217	2	150/9	3	HE 217	2 7/8	HS 217	75	H 217
3 1/16	SN 1518-S-3 1/16	SN 518-S	1218-K	9700	HA 218	2	160/16.2					80	H 218
3 1/4	SN 1519-S-3 1/4	SN 519-S	1219-K	11000	HE 219	2	170/10					85	H 219
3 7/16	SN 1520-S-3 7/16	SN 520-S	1220-K	11900	HA 220	2	180/12	3 1/2	HE 220			90	H 220
3 15/16	SN 1522-S-3 15/16	SN 522-S	1222-K	15000	HA 222	1	200/15	4	HE 222	3 7/8	HS 222	100	H 222

SERIES **SN 1600-S**

**SOLID BASE - CAST IRON - 2 BOLT HOLES**

Standard Shaft dia. inch	Complete Pillow Block number	COMPONENT PART NUMBERS						Alternative Shaft Sizes					
		Housing number	Bearing		Adapter sleeve number	Fixing rings (No. req'd.)		dia. inch	Adapter number	dia. inch	Adapter number	dia. mm	Adapter number
			Bearing number	Dyn. Load Rtg. Lbs.									
3/4	SN 1605-S-3/4	SN 605-S	1305-K	3080	HE 305	2	62/8.5					20	H 305
15/16	SN 1606-S-15/16	SN 606-S	1306-K	3660	HA 306	2	72/9	1	HE 306			25	H 306
13/16	SN 1607-S-13/16	SN 607-S	1307-K	4350	HA 307	2	80/10					30	H 307
15/16	SN 1608-S-15/16	SN 608-S	1308-K	5100	HA 308	2	90/10	1 1/4	HE 308	1 3/8	HS 308	35	H 308
1 1/16	SN 1609-S-1 1/16	SN 609-S	1309-K	6600	HA 309	2	100/10.5	1 1/2	HE 309			40	H 309
1 1/8	SN 1610-S-1 1/8	SN 610-S	1310-K	7500	HA 310	2	110/11.5	1 3/4	HE 310	1 5/8	HS 310	45	H 310
1 1/4	SN 1611-S-1 1/4	SN 611-S	1311-K	8800	HA 311	2	120/12	2	HE 311	1 7/8	HS 311	50	H 311
2 1/16	SN 1612-S-2 1/16	SN 612-S	1312-K	9900	HA 312	2	130/12.5			2 1/8	HS 312	55	H 312
2 3/16	SN 1613-S-2 3/16	SN 613-S	1313-K	10600	HA 313	2	140/12.5	2 1/4	HE 313	2 3/8	HS 313	60	H 313
2 7/16	SN 1615-S-2 7/16	SN 615-S	1315-K	13700	HA 315	2	160/14	2 1/2	HE 315			65	H 315
2 11/16	SN 1616-S-2 11/16	SN 616-S	1316-K	15300	HA 316	2	170/14.5	2 3/4	HE 316			70	H 316
2 15/16	SN 1617-S-2 15/16	SN 617-S	1317-K	16900	HA 317	2	180/14.5	3	HE 317	2 7/8	HS 317	75	H 317
3 1/16	SN 1618-S-3 1/16	SN 618-S	1318-K	20100	HA 318	2	190/15.5	3 1/4	HE 318	3 1/8	HS 318	80	H 318
3 1/4	SN 1619-S-3 1/4	SN 619-S	1319-K	22880	HE 319	2	200/16					85	H 319
3 7/16	SN 1620-S-3 7/16	SN 620-S	1320-K	24700	HA 320	2	215/18	3 1/2	HE 320	3 5/8	HS 320	90	H 320
3 15/16	SN 1622-S-3 15/16	SN 622-S	1322-K	28400	HA 322	2	240/20	4	HE 322	3 7/8	HS 322	100	H 322

# ringball bearings ltd.

**RBL SPLIT HOUSINGS**

SERIES

**SN 500-S**

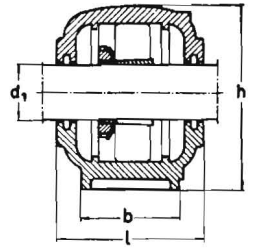
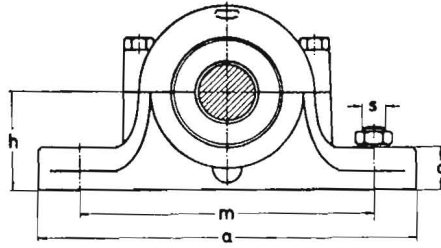

Housing number	h inch	a inch	m inch	l inch	b inch	c inch	h <sub>1</sub> inch	s inch	for shaft sizes			
									inch		mm	
SN 505-S	1.575	6 1/2	5 1/8	2 5/8	1 13/16	3/4	3	1/2		3/4	7/8	20
SN 506-S	1.969	7 5/16	5 5/16	3	2 1/16	7/8	3 1/2	1/2	1 5/16	1	7/8	25
SN 507-S	1.969	7 5/16	5 5/16	3 1/4	2 1/16	7/8	3 3/4	1/2	1 3/16		1 1/8	30
SN 508-S	2.362	8 1/16	6 1 1/16	3 3/8	2 3/8	1	4 3/8	1/2	1 7/16	1 1/4	1 3/8	35
SN 509-S	2.362	8 1/16	6 1 1/16	3 3/8	2 3/8	1	4 3/8	1/2	1 7/16	1 1/2		40
SN 510-S	2.362	8 1/16	6 1 1/16	3 3/16	2 3/8	1	4 1/2	1/2	1 1 1/16	1 3/4	1 5/8	45
SN 511-S	2.756	10	8 1/4	3 3/4	2 3/4	1 1/8	5 1/8	5/8	1 5/16	2	1 7/8	50
SN 512-S	2.756	10	8 1/4	4 1/8	2 3/4	1 3/16	5 5/16	5/8	2 1/16			55
SN 513-S	3.150	10 7/8	9	4 3/8	3 1/8	1 3/16	5 7/8	3/8	2 3/16	2 1/4	2 3/8	60
SN 515-S	3.150	11	9	4 1/2	3 1/8	1 3/16	6 1/8	5/8	2 7/16	2 1/2		65
SN 516-S	3.740	12 3/8	10 1/4	4 3/4	3 1/2	1 1/4	6 7/8	3/4	2 1 1/16	2 3/4		70
SN 517-S	3.740	12 5/8	10 1/4	5	3 1/2	1 1/4	7 1/4	3/4	2 5/16	3	2 7/8	75
SN 518-S	3.937	13 5/8	11 7/16	5 3/4	4	1 3/8	7 3/4	3/4	3 3/16			80
SN 519-S	4.409	13 1/2	11 7/16	5 1/2	4	1 3/8	8 1/4	3/4		3 1/4		85
SN 520-S	4.409	15	12 1/2	6 1/4	4 3/8	1 1/2	8 1/2	7/8	3 7/16	3 1/2		90
SN 522-S	4.921	16 1/8	13 3/4	6 7/8	4 3/4	1 3/4	9 1/2	7/8	3 5/16	4	3 7/8	100

SERIES

**SN 600-S**

Housing number	h inch	a inch	m inch	l inch	b inch	c inch	h <sub>1</sub> inch	s inch	for shaft sizes			
									inch		mm	
SN 605-S	1.969	7 1/4	6	3 3/16	2	7/8	3 1/2	1/2		3/4		20
SN 606-S	1.969	7 1/4	6	3 3/16	2	7/8	3 3/4	1/2	1 5/16	1		25
SN 607-S	2.362	8	6 1 1/16	3 1/2	2 3/8	1	4 3/8	1/2	1 3/16			30
SN 608-S	2.362	8	6 1 1/16	3 3/4	2 3/8	1	4 1/2	1/2	1 5/16	1 1/4	1 3/8	35
SN 609-S	2.756	10	8 1/4	4 1/8	2 3/4	1 1/8	5 1/8	5/8	1 7/16	1 1/2		40
SN 610-S	2.756	10	8 1/4	4 1/2	2 3/4	1 1/8	5 3/8	5/8	1 1 1/16	1 3/4	1 5/8	45
SN 611-S	3.150	11	9	4 3/4	3 1/8	1 1/8	5 7/8	5/8	1 5/16	2	1 7/8	50
SN 612-S	3.150	11	9	5	3 1/8	1 1/8	6 1/8	5/8	2 1/16		2 1/8	55
SN 613-S	3.740	12 3/8	10 1/4	5 1/8	3 1/2	1 1/4	6 7/8	3/4	2 3/16	2 1/4	2 3/8	60
SN 615-S	3.937	13 5/8	11 7/16	5 1/2	4	1 3/8	7 3/4	3/4	2 7/16	2 1/2		65
SN 616-S	4.409	13 5/8	11 7/16	5 3/4	4	1 3/8	8 1/4	3/4	2 1 1/16	2 3/4		70
SN 617-S	4.409	15	12 1/2	6 1/8	4 3/8	1 1/2	8 1/2	7/8	2 5/16	3	2 7/8	75
SN 618-S	4.409	15	12 1/2	6 1/4	4 3/8	1 1/2	8 7/8	7/8	3 3/16	3 1/4	3 1/8	80
SN 619-S	4.921	16 1/8	13 3/4	6 1 1/16	4 3/4	1 3/4	9 1/2	7/8		3 1/4		85
SN 620-S	5.512	16 1/8	13 3/4	6 7/8	4 3/4	1 3/4	10 1/4	7/8	3 7/16	3 1/2	3 5/8	90
SN 622-S	5.906	17 1/2	15 3/8	7 1/2	5 1/8	2	11 1/16	7/8	3 5/16	4	3 7/8	100

# ringball bearings Ltd.

**RBL** SPLIT HOUSING PILLOW BLOCKS  
for spherical roller bearings  
with adapter sleeves

SERIES

**SN 22500-S**

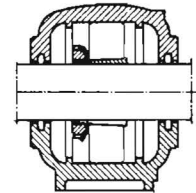
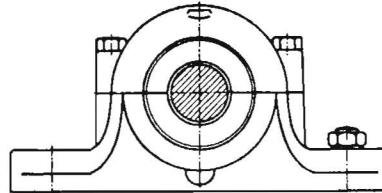

## SOLID BASE - CAST IRON - 2 BOLT HOLES

Standard Shaft dia. inch	Complete Pillow Back number	COMPONENT PART NUMBERS						Alternative Shaft Sizes					
		Housing number	Bearing		Adapter sleeve number	Fixing rings (No. req'd.)		dia. inch	Adapter number	dia. inch	Adapter number	dia. mm	Adapter number
			Bearing number	Dyn. Load Rtg. Lbs.									
1 <sup>5</sup> / <sub>16</sub>	SN 22508-S-1 <sup>5</sup> / <sub>16</sub>	SN 508-S	22208-CK	13450	HA 308	1	80/10	1 <sup>1</sup> / <sub>4</sub>	HE 308	1 <sup>3</sup> / <sub>8</sub>	HS 308	35	H 308
1 <sup>7</sup> / <sub>16</sub>	SN 22509-S-1 <sup>7</sup> / <sub>16</sub>	SN 509-S	22209-CK	14400	HA 309	1	85/8	1 <sup>1</sup> / <sub>2</sub>	HE 309			40	H 309
1 <sup>1</sup> / <sub>2</sub>	SN 22510-S-1 <sup>1</sup> / <sub>2</sub>	SN 510-S	22210-CK	15700	HA 310	1	90/10	1 <sup>3</sup> / <sub>4</sub>	HE 310	1 <sup>5</sup> / <sub>8</sub>	HS 310	45	H 310
1 <sup>5</sup> / <sub>8</sub>	SN 22511-S-1 <sup>5</sup> / <sub>8</sub>	SN 511-S	22211-CK	18800	HA 311	1	100/8	2	HE 311	1 <sup>7</sup> / <sub>8</sub>	HS 311	50	H 311
2 <sup>1</sup> / <sub>16</sub>	SN 22512-S-2 <sup>1</sup> / <sub>16</sub>	SN 512-S	22212-CK	22700	HA 312	1	110/10			2 <sup>1</sup> / <sub>8</sub>	HS 312	55	H 312
2 <sup>3</sup> / <sub>16</sub>	SN 22513-S-2 <sup>3</sup> / <sub>16</sub>	SN 513-S	22213-CK	26900	HA 313	1	120/12	2 <sup>1</sup> / <sub>4</sub>	HE 313	2 <sup>3</sup> / <sub>8</sub>	HS 313	60	H 313
2 <sup>7</sup> / <sub>16</sub>	SN 22515-S-2 <sup>7</sup> / <sub>16</sub>	SN 515-S	22215-CK	30200	HA 315	1	130/10	2 <sup>1</sup> / <sub>2</sub>	HE 315			65	H 315
2 <sup>1</sup> / <sub>2</sub>	SN 22516-S-2 <sup>1</sup> / <sub>2</sub>	SN 516-S	22216-CK	34400	HA 316	1	140/10	2 <sup>3</sup> / <sub>4</sub>	HE 316			70	H 316
2 <sup>5</sup> / <sub>16</sub>	SN 22517-S-2 <sup>5</sup> / <sub>16</sub>	SN 517-S	22217-CK	39700	HA 317	1	150/10	3	HE 317	2 <sup>7</sup> / <sub>8</sub>	HS 317	75	H 317
3 <sup>3</sup> / <sub>16</sub>	SN 22518-S-3 <sup>3</sup> / <sub>16</sub>	SN 518-S	22218-CK	47600	HA 318	2	160/11.2	3 <sup>1</sup> / <sub>4</sub>	HE 318	3 <sup>3</sup> / <sub>8</sub>	HS 318	80	H 318
3 <sup>1</sup> / <sub>4</sub>	SN 22519-S-3 <sup>1</sup> / <sub>4</sub>	SN 519-S	22219-CK	54000	HE 319	1	170/10					85	H 319
3 <sup>7</sup> / <sub>16</sub>	SN 22520-S-3 <sup>7</sup> / <sub>16</sub>	SN 520-S	22220-CK	60600	HA 320	2	180/12.1	3 <sup>1</sup> / <sub>2</sub>	HE 320	3 <sup>5</sup> / <sub>8</sub>	HS 320	90	H 320
3 <sup>5</sup> / <sub>8</sub>	SN 22522-S-3 <sup>5</sup> / <sub>8</sub>	SN 522-S	22222-CK	79400	HA 322	2	200/13.5	4	HE 322	3 <sup>7</sup> / <sub>8</sub>	HS 322	100	H 322
4 <sup>3</sup> / <sub>16</sub>	SN 22524-S-4 <sup>3</sup> / <sub>16</sub>	SN 524-S	22224-CK	91500	HA 3124	2	215/14	4 <sup>1</sup> / <sub>4</sub>	HE 3124			110	H 3124
4 <sup>7</sup> / <sub>16</sub>	SN 22526-S-4 <sup>7</sup> / <sub>16</sub>	SN 526-S	22226-CK	108000	HA 3126	2	230/13	4 <sup>1</sup> / <sub>2</sub>	HE 3126			115	H 3126
4 <sup>5</sup> / <sub>8</sub>	SN 22528-S-4 <sup>5</sup> / <sub>8</sub>	SN 528-S	22228-CK	121300	HA 3128	2	250/15	5	HE 3128			125	H 3128
5 <sup>3</sup> / <sub>16</sub>	SN 22530-S-5 <sup>3</sup> / <sub>16</sub>	SN 530-S	22230-CK	144000	HA 3130	2	270/16.5	5 <sup>1</sup> / <sub>4</sub>	HE 3130			135	H 3130
5 <sup>7</sup> / <sub>16</sub>	SN 22532-S-5 <sup>7</sup> / <sub>16</sub>	SN 532-S	22232-CK	160600	HA 3132	2	290/17	5 <sup>1</sup> / <sub>2</sub>	HE 3132			140	H 3132

# ringball bearings Ltd.

**RBL SPLIT HOUSINGS**

SERIES

**SN 500-S**

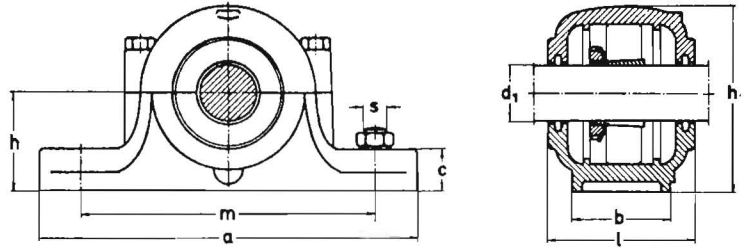

Housing number	h inch	a inch	m inch	l inch	b inch	c inch	h <sub>1</sub> inch	s inch	for shaft sizes			
									inch		mm	
SN 508-S	2.362	8 <sup>1</sup> / <sub>16</sub>	6 <sup>11</sup> / <sub>16</sub>	3 <sup>3</sup> / <sub>8</sub>	2 <sup>3</sup> / <sub>8</sub>	1	4 <sup>3</sup> / <sub>8</sub>	1/2	1 <sup>5</sup> / <sub>16</sub>	1 <sup>1</sup> / <sub>4</sub>	1 <sup>1</sup> / <sub>8</sub>	35
SN 509-S	2.362	8 <sup>1</sup> / <sub>16</sub>	6 <sup>11</sup> / <sub>16</sub>	3 <sup>3</sup> / <sub>8</sub>	2 <sup>3</sup> / <sub>8</sub>	1	4 <sup>3</sup> / <sub>8</sub>	1/2	1 <sup>7</sup> / <sub>16</sub>	1 <sup>1</sup> / <sub>2</sub>		40
SN 510-S	2.362	8 <sup>1</sup> / <sub>16</sub>	6 <sup>11</sup> / <sub>16</sub>	3 <sup>9</sup> / <sub>16</sub>	2 <sup>3</sup> / <sub>8</sub>	1	4 <sup>1</sup> / <sub>2</sub>	1/2	1 <sup>11</sup> / <sub>16</sub>	1 <sup>3</sup> / <sub>4</sub>	1 <sup>5</sup> / <sub>8</sub>	45
SN 511-S	2.756	10	8 <sup>1</sup> / <sub>4</sub>	3 <sup>3</sup> / <sub>4</sub>	2 <sup>3</sup> / <sub>4</sub>	1 <sup>1</sup> / <sub>8</sub>	5 <sup>1</sup> / <sub>8</sub>	5/8	1 <sup>9</sup> / <sub>16</sub>	2	1 <sup>1</sup> / <sub>8</sub>	50
SN 512-S	2.756	10	8 <sup>1</sup> / <sub>4</sub>	4 <sup>1</sup> / <sub>8</sub>	2 <sup>3</sup> / <sub>4</sub>	1 <sup>3</sup> / <sub>16</sub>	5 <sup>5</sup> / <sub>16</sub>	5/8	2 <sup>1</sup> / <sub>16</sub>		2 <sup>1</sup> / <sub>8</sub>	55
SN 513-S	3.150	10 <sup>7</sup> / <sub>8</sub>	9	4 <sup>3</sup> / <sub>8</sub>	3 <sup>1</sup> / <sub>8</sub>	1 <sup>3</sup> / <sub>16</sub>	5 <sup>7</sup> / <sub>8</sub>	7/8	2 <sup>3</sup> / <sub>16</sub>	2 <sup>1</sup> / <sub>4</sub>	2 <sup>3</sup> / <sub>8</sub>	60
SN 515-S	3.150	11	9	4 <sup>1</sup> / <sub>2</sub>	3 <sup>1</sup> / <sub>8</sub>	1 <sup>3</sup> / <sub>16</sub>	6 <sup>1</sup> / <sub>8</sub>	5/8	2 <sup>7</sup> / <sub>16</sub>	2 <sup>1</sup> / <sub>2</sub>		65
SN 516-S	3.740	12 <sup>3</sup> / <sub>8</sub>	10 <sup>1</sup> / <sub>4</sub>	4 <sup>3</sup> / <sub>4</sub>	3 <sup>1</sup> / <sub>2</sub>	1 <sup>1</sup> / <sub>4</sub>	6 <sup>7</sup> / <sub>8</sub>	3/4	2 <sup>1</sup> / <sub>16</sub>	2 <sup>3</sup> / <sub>4</sub>		70
SN 517-S	3.740	12 <sup>3</sup> / <sub>8</sub>	10 <sup>1</sup> / <sub>4</sub>	5	3 <sup>1</sup> / <sub>2</sub>	1 <sup>1</sup> / <sub>4</sub>	7 <sup>1</sup> / <sub>4</sub>	3/4	2 <sup>15</sup> / <sub>16</sub>	3	2 <sup>7</sup> / <sub>8</sub>	75
SN 518-S	3.937	13 <sup>5</sup> / <sub>8</sub>	11 <sup>7</sup> / <sub>16</sub>	5 <sup>3</sup> / <sub>4</sub>	4	1 <sup>3</sup> / <sub>8</sub>	7 <sup>3</sup> / <sub>4</sub>	3/4	3 <sup>3</sup> / <sub>16</sub>	3 <sup>1</sup> / <sub>4</sub>	3 <sup>1</sup> / <sub>8</sub>	80
SN 519-S	4.409	13 <sup>1</sup> / <sub>2</sub>	11 <sup>7</sup> / <sub>16</sub>	5 <sup>1</sup> / <sub>2</sub>	4	1 <sup>3</sup> / <sub>8</sub>	8 <sup>1</sup> / <sub>4</sub>	3/4		3 <sup>1</sup> / <sub>4</sub>		85
SN 520-S	4.409	15	12 <sup>1</sup> / <sub>2</sub>	6 <sup>1</sup> / <sub>4</sub>	4 <sup>3</sup> / <sub>8</sub>	1 <sup>1</sup> / <sub>2</sub>	8 <sup>1</sup> / <sub>2</sub>	7/8	3 <sup>7</sup> / <sub>16</sub>	3 <sup>1</sup> / <sub>2</sub>	3 <sup>5</sup> / <sub>8</sub>	90
SN 522-S	4.921	16 <sup>1</sup> / <sub>8</sub>	13 <sup>3</sup> / <sub>4</sub>	6 <sup>7</sup> / <sub>8</sub>	4 <sup>3</sup> / <sub>4</sub>	1 <sup>3</sup> / <sub>4</sub>	9 <sup>1</sup> / <sub>2</sub>	7/8	3 <sup>15</sup> / <sub>16</sub>	4	3 <sup>7</sup> / <sub>8</sub>	100
SN 524-S	5.512	16 <sup>1</sup> / <sub>8</sub>	13 <sup>3</sup> / <sub>4</sub>	7 <sup>1</sup> / <sub>4</sub>	4 <sup>3</sup> / <sub>4</sub>	1 <sup>3</sup> / <sub>4</sub>	10 <sup>5</sup> / <sub>8</sub>	7/8	4 <sup>3</sup> / <sub>16</sub>	4 <sup>1</sup> / <sub>4</sub>		110
SN 526-S	5.906	17 <sup>1</sup> / <sub>2</sub>	15	7 <sup>1</sup> / <sub>2</sub>	5 <sup>1</sup> / <sub>8</sub>	2	11 <sup>1</sup> / <sub>2</sub>	1	4 <sup>7</sup> / <sub>16</sub>	4 <sup>1</sup> / <sub>2</sub>		115
SN 528-S	5.906	19 <sup>3</sup> / <sub>4</sub>	16 <sup>1</sup> / <sub>2</sub>	8 <sup>1</sup> / <sub>8</sub>	5 <sup>7</sup> / <sub>8</sub>	2	12	1 <sup>1</sup> / <sub>4</sub>	4 <sup>15</sup> / <sub>16</sub>	5		125
SN 530-S	6.299	20 <sup>7</sup> / <sub>8</sub>	17 <sup>3</sup> / <sub>4</sub>	8 <sup>5</sup> / <sub>8</sub>	6 <sup>3</sup> / <sub>8</sub>	2 <sup>3</sup> / <sub>8</sub>	12 <sup>3</sup> / <sub>4</sub>	1 <sup>1</sup> / <sub>4</sub>	5 <sup>3</sup> / <sub>16</sub>	5 <sup>1</sup> / <sub>4</sub>		135
SN 532-S	6.693	21 <sup>5</sup> / <sub>8</sub>	18 <sup>1</sup> / <sub>2</sub>	9 <sup>1</sup> / <sub>4</sub>	6 <sup>3</sup> / <sub>8</sub>	2 <sup>3</sup> / <sub>8</sub>	13 <sup>3</sup> / <sub>8</sub>	1 <sup>1</sup> / <sub>4</sub>	5 <sup>7</sup> / <sub>16</sub>	5 <sup>1</sup> / <sub>2</sub>		140

# ringball bearings Ltd.

## RBL SPLIT HOUSING PILLOW BLOCKS for spherical roller bearings with adapter sleeves

SERIES

**SN 22600-S**

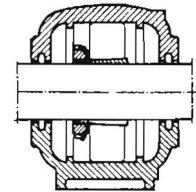
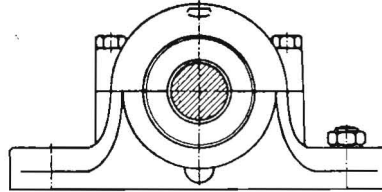

## SOLID BASE - CAST IRON - 2 BOLT HOLES

Standard Shaft dia. inch	Complete Pillow Block number	COMPONENT PART NUMBERS					Alternative Shaft Sizes						
		Housing number	Bearing		Adapter sleeve number	Fixing rings (No. req'd.)	dia. inch	Adapter number	dia. inch	Adapter number	dia. mm	Adapter number	
			Bearing number	Dyn. Load Rtg. Lbs.									
1/4	SN 22608-S-1/4	SN 608-S	22308-CK	21600	HE 2308	1	90/10					35	H 2308
1/16	SN 22609-S-1/16	SN 609-S	22309-CK	26500	HA 2309	1	100/10	1 1/2	HE 2309			40	H 2309
1 1/16	SN 22610-S-1 1/16	SN 610-S	22310-CK	33700	HA 2310	1	110/10	1 3/4	HE 2310	1 5/8	HS 2310	45	H 2310
1 3/16	SN 22611-S-1 3/16	SN 611-S	22311-CK	38800	HA 2311	1	120/10	2	HE 2311	1 7/8	HS 2311	50	H 2311
2 1/16	SN 22612-S-2 1/16	SN 612-S	22312-CK	44100	HA 2312	1	130/10			2 1/8	HS 2312	55	H 2312
2 3/16	SN 22613-S-2 3/16	SN 613-S	22313-CK	48500	HA 2313	1	140/10	2 1/4	HE 2313	2 3/8	HS 2313	60	H 2313
2 7/16	SN 22615-S-2 7/16	SN 615-S	22315-CK	66100	HA 2315	1	160/10	2 1/2	HE 2315	2 5/8	HS 2315	65	H 2315
2 11/16	SN 22616-S-2 11/16	SN 616-S	22316-CK	71600	HA 2316	1	170/10	2 3/4	HE 2316	2 7/8	HS 2316	70	H 2316
2 15/16	SN 22617-S-2 15/16	SN 617-S	22317-CK	73900	HA 2317	1	180/10	3	HE 2317			75	H 2317
3 1/16	SN 22618-S-3 1/16	SN 618-S	22318-CK	89300	HA 2318	1	190/10	3 1/4	HE 2318	3 1/8	HS 2318	80	H 2318
3 5/16	SN 22619-S-3 5/16	SN 619-S	22319-CK	97000	HA 2319	1	200/10	3 1/4	HE 2319			85	H 2319
3 7/16	SN 22620-S-3 7/16	SN 620-S	22320-CK	115000	HA 2320	1	215/10	3 1/2	HE 2320	3 5/8	HS 2320	90	H 2320
3 15/16	SN 22622-S-3 15/16	SN 622-S	22322-CK	137000	HA 2322	1	240/10	4	HE 2322	3 7/8	HS 2322	100	H 2322
4 3/16	SN 22624-S-4 3/16	SN 624-S	22324-CK	159000	HA 2324	1	260/10	4 1/4	HE 2324			110	H 2324
4 7/16	SN 22626-S-4 7/16	SN 626-S	22326-CK	183000	HA 2326	1	280/10	4 1/2	HE 2326			115	H 2326
4 15/16	SN 22628-S-4 15/16	SN 628-S	22328-CK	209000	HA 2328	1	300/10	5	HE 2328			125	H 2328

# ringball bearings Ltd.

**RBL SPLIT HOUSINGS**

SERIES

**SN 600-S**

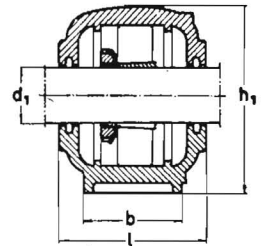
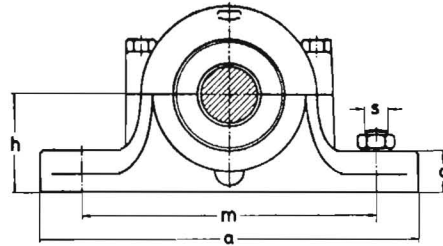

Housing number	h inch	a inch	m inch	l inch	b inch	c inch	h <sub>1</sub> inch	s inch	for shaft sizes			
									inch		mm	
SN 608-S	2.362	8	6 <sup>11</sup> / <sub>16</sub>	3 <sup>3</sup> / <sub>4</sub>	2 <sup>3</sup> / <sub>8</sub>	1	4 <sup>1</sup> / <sub>2</sub>	1/2	1 <sup>5</sup> / <sub>16</sub>	1 <sup>1</sup> / <sub>4</sub>		35
SN 609-S	2.756	10	8 <sup>1</sup> / <sub>4</sub>	4 <sup>1</sup> / <sub>8</sub>	2 <sup>3</sup> / <sub>4</sub>	1 <sup>1</sup> / <sub>8</sub>	5 <sup>1</sup> / <sub>8</sub>	5/8	1 <sup>7</sup> / <sub>16</sub>	1 <sup>1</sup> / <sub>2</sub>		40
SN 610-S	2.756	10	8 <sup>1</sup> / <sub>4</sub>	4 <sup>1</sup> / <sub>2</sub>	2 <sup>3</sup> / <sub>4</sub>	1 <sup>1</sup> / <sub>8</sub>	5 <sup>3</sup> / <sub>8</sub>	5/8	1 <sup>11</sup> / <sub>16</sub>	1 <sup>3</sup> / <sub>4</sub>	1 <sup>5</sup> / <sub>8</sub>	45
SN 611-S	3.150	11	9	4 <sup>3</sup> / <sub>4</sub>	3 <sup>1</sup> / <sub>8</sub>	1 <sup>1</sup> / <sub>8</sub>	5 <sup>7</sup> / <sub>8</sub>	5/8	1 <sup>15</sup> / <sub>16</sub>	2	1 <sup>7</sup> / <sub>8</sub>	50
SN 612-S	3.150	11	9	5	3 <sup>1</sup> / <sub>8</sub>	1 <sup>1</sup> / <sub>8</sub>	6 <sup>1</sup> / <sub>8</sub>	5/8	2 <sup>3</sup> / <sub>16</sub>		2 <sup>1</sup> / <sub>8</sub>	55
SN 613-S	3.740	12 <sup>3</sup> / <sub>8</sub>	10 <sup>1</sup> / <sub>4</sub>	5 <sup>5</sup> / <sub>8</sub>	3 <sup>1</sup> / <sub>2</sub>	1 <sup>1</sup> / <sub>4</sub>	6 <sup>7</sup> / <sub>8</sub>	3/4	2 <sup>3</sup> / <sub>16</sub>	2 <sup>1</sup> / <sub>4</sub>	2 <sup>3</sup> / <sub>8</sub>	60
SN 615-S	3.937	13 <sup>5</sup> / <sub>8</sub>	11 <sup>7</sup> / <sub>16</sub>	5 <sup>1</sup> / <sub>2</sub>	4	1 <sup>3</sup> / <sub>8</sub>	7 <sup>3</sup> / <sub>4</sub>	3/4	2 <sup>7</sup> / <sub>16</sub>	2 <sup>1</sup> / <sub>2</sub>	2 <sup>5</sup> / <sub>8</sub>	65
SN 616-S	4.409	13 <sup>5</sup> / <sub>8</sub>	11 <sup>7</sup> / <sub>16</sub>	5 <sup>3</sup> / <sub>4</sub>	4	1 <sup>3</sup> / <sub>8</sub>	8 <sup>1</sup> / <sub>4</sub>	3/4	2 <sup>11</sup> / <sub>16</sub>	2 <sup>3</sup> / <sub>4</sub>	2 <sup>7</sup> / <sub>8</sub>	70
SN 617-S	4.409	15	12 <sup>1</sup> / <sub>2</sub>	6 <sup>1</sup> / <sub>8</sub>	4 <sup>3</sup> / <sub>8</sub>	1 <sup>1</sup> / <sub>2</sub>	8 <sup>1</sup> / <sub>2</sub>	7/8	2 <sup>15</sup> / <sub>16</sub>	3		75
SN 618-S	4.409	15	12 <sup>1</sup> / <sub>2</sub>	6 <sup>1</sup> / <sub>4</sub>	4 <sup>3</sup> / <sub>8</sub>	1 <sup>1</sup> / <sub>2</sub>	8 <sup>7</sup> / <sub>8</sub>	7/8	3 <sup>3</sup> / <sub>16</sub>	3 <sup>1</sup> / <sub>4</sub>	3 <sup>3</sup> / <sub>8</sub>	80
SN 619-S	4.921	16 <sup>1</sup> / <sub>8</sub>	13 <sup>3</sup> / <sub>4</sub>	6 <sup>11</sup> / <sub>16</sub>	4 <sup>3</sup> / <sub>4</sub>	1 <sup>3</sup> / <sub>4</sub>	9 <sup>1</sup> / <sub>2</sub>	7/8	3 <sup>5</sup> / <sub>16</sub>	3 <sup>3</sup> / <sub>4</sub>		85
SN 620-S	5.512	16 <sup>1</sup> / <sub>8</sub>	13 <sup>3</sup> / <sub>4</sub>	6 <sup>7</sup> / <sub>8</sub>	4 <sup>3</sup> / <sub>4</sub>	1 <sup>3</sup> / <sub>4</sub>	10 <sup>1</sup> / <sub>4</sub>	7/8	3 <sup>7</sup> / <sub>16</sub>	3 <sup>1</sup> / <sub>2</sub>	3 <sup>5</sup> / <sub>8</sub>	90
SN 622-S	5.906	17 <sup>1</sup> / <sub>2</sub>	15 <sup>3</sup> / <sub>8</sub>	7 <sup>1</sup> / <sub>2</sub>	5 <sup>5</sup> / <sub>8</sub>	2	11 <sup>7</sup> / <sub>16</sub>	7/8	3 <sup>15</sup> / <sub>16</sub>	4	3 <sup>7</sup> / <sub>8</sub>	100
SN 624-S	6.299	20 <sup>7</sup> / <sub>8</sub>	17 <sup>3</sup> / <sub>4</sub>	8	6 <sup>1</sup> / <sub>4</sub>	2 <sup>3</sup> / <sub>8</sub>	12 <sup>9</sup> / <sub>16</sub>	1 <sup>1</sup> / <sub>8</sub>	4 <sup>3</sup> / <sub>16</sub>	4 <sup>1</sup> / <sub>4</sub>		110
SN 626-S	6.693	21 <sup>1</sup> / <sub>8</sub>	18 <sup>1</sup> / <sub>2</sub>	8 <sup>1</sup> / <sub>2</sub>	6 <sup>1</sup> / <sub>4</sub>	2 <sup>3</sup> / <sub>8</sub>	13 <sup>3</sup> / <sub>16</sub>	1 <sup>1</sup> / <sub>8</sub>	4 <sup>7</sup> / <sub>16</sub>	4 <sup>1</sup> / <sub>2</sub>		115
SN 628-S	7.087	24 <sup>1</sup> / <sub>2</sub>	20 <sup>1</sup> / <sub>2</sub>	9 <sup>1</sup> / <sub>4</sub>	6 <sup>11</sup> / <sub>16</sub>	2 <sup>3</sup> / <sub>8</sub>	14 <sup>3</sup> / <sub>16</sub>	1 <sup>1</sup> / <sub>8</sub>	4 <sup>15</sup> / <sub>16</sub>	5		125

# ringball bearings Ltd.

## RBL SPLIT HOUSING PILLOW BLOCKS for self-aligning ball bearings with adapter sleeves

SERIES **SSN 1500**

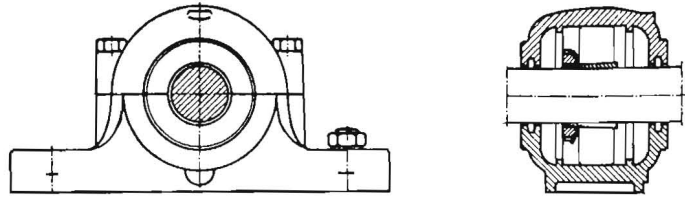

### SOLID BASE - CAST IRON - Suitable for 2 or 4 Bolt Drilling

Standard Shaft dia. inch	Complete Pillow Block number	COMPONENT PART NUMBERS						Alternative Shaft Sizes					
		Housing number	Bearing		Adapter sleeve number	Fixing rings (No. req'd.)		dia. inch	Adapter number	dia. inch	Adapter number	dia. mm	Adapter number
			Bearing number	Dyn. Load Rtg. Lbs.									
1 <sup>5</sup> / <sub>16</sub>	SSN 1511-1 <sup>5</sup> / <sub>16</sub>	SSN 511	1211 K	4600	HA 211	2	100/6	2	HE 211	1 <sup>7</sup> / <sub>8</sub>	HS 211	50	H 211
2 <sup>3</sup> / <sub>16</sub>	SSN 1513-2 <sup>3</sup> / <sub>16</sub>	SSN 513	1213 K	5300	HA 213	2	120/10	2 <sup>1</sup> / <sub>4</sub>	HE 213	2 <sup>3</sup> / <sub>8</sub>	HS 213	60	H 213
2 <sup>7</sup> / <sub>16</sub>	SSN 1515-2 <sup>7</sup> / <sub>16</sub>	SSN 515	1215-K	6700	HA 215	2	130/8	2 <sup>1</sup> / <sub>2</sub>	HE 215			65	H 215
2 <sup>1</sup> / <sub>16</sub>	SSN 1516-2 <sup>1</sup> / <sub>16</sub>	SSN 516	1216-K	6800	HA 216	2	140/8.5	2 <sup>3</sup> / <sub>4</sub>	HE 216			70	H 216
2 <sup>5</sup> / <sub>16</sub>	SSN 1517-2 <sup>5</sup> / <sub>16</sub>	SSN 517	1217-K	8400	HA 217	2	150/9	3	HE 217	2 <sup>7</sup> / <sub>8</sub>	HS 217	75	H 217
3 <sup>3</sup> / <sub>16</sub>	SSN 1518-3 <sup>3</sup> / <sub>16</sub>	SSN 518	1218-K	9700	HA 218	2	160/16.2					80	H 218
3 <sup>7</sup> / <sub>16</sub>	SSN 1520-3 <sup>7</sup> / <sub>16</sub>	SSN 520	1220-K	11900	HA 220	2	180/12	3 <sup>1</sup> / <sub>2</sub>	HE 220			90	H 220
3 <sup>1</sup> / <sub>16</sub>	SSN 1522-3 <sup>1</sup> / <sub>16</sub>	SSN 522	1222-K	15000	HA 222	1	200/15	4	HE 222	3 <sup>7</sup> / <sub>8</sub>	HS 222	100	H 222

## RBL SPLIT HOUSING PILLOW BLOCKS for spherical roller bearings with adapter sleeves

SERIES **SSN 22500**

### SOLID BASE - CAST IRON - Suitable for 2 or 4 Bolt Drilling

Standard Shaft dia. inch	Complete Pillow Block number	COMPONENT PART NUMBERS						Alternative Shaft Sizes					
		Housing number	Bearing		Adapter sleeve number	Fixing rings (No. req'd.)		dia. inch	Adapter number	dia. inch	Adapter number	dia. mm	Adapter number
			Bearing number	Dyn. Load Rtg. Lbs.									
1 <sup>5</sup> / <sub>16</sub>	SSN 22511-1 <sup>5</sup> / <sub>16</sub>	SSN 511	22211-CK	18800	HA 311	1	100/8	2	HE 311	1 <sup>7</sup> / <sub>8</sub>	HS 311	50	H 311
2 <sup>3</sup> / <sub>16</sub>	SSN 22513-2 <sup>3</sup> / <sub>16</sub>	SSN 513	22213-CK	26900	HA 313	1	120/12	2 <sup>1</sup> / <sub>4</sub>	HE 313	2 <sup>3</sup> / <sub>8</sub>	HS 313	60	H 313
2 <sup>7</sup> / <sub>16</sub>	SSN 22515-2 <sup>7</sup> / <sub>16</sub>	SSN 515	22215-CK	30200	HA 315	1	130/10	2 <sup>1</sup> / <sub>2</sub>	HE 315			65	H 315
2 <sup>1</sup> / <sub>16</sub>	SSN 22516-2 <sup>1</sup> / <sub>16</sub>	SSN 516	22216-CK	34400	HA 316	1	140/10	2 <sup>3</sup> / <sub>4</sub>	HE 316			70	H 316
2 <sup>5</sup> / <sub>16</sub>	SSN 22517-2 <sup>5</sup> / <sub>16</sub>	SSN 517	22217-CK	39700	HA 317	1	150/10	3	HE 317	2 <sup>7</sup> / <sub>8</sub>	HS 317	75	H 317
3 <sup>3</sup> / <sub>16</sub>	SSN 22518-3 <sup>3</sup> / <sub>16</sub>	SSN 518	22218-CK	47600	HA 318	2	160/11.2	3 <sup>1</sup> / <sub>4</sub>	HE 318	3 <sup>1</sup> / <sub>8</sub>	HS 318	80	H 318
3 <sup>7</sup> / <sub>16</sub>	SSN 22520-3 <sup>7</sup> / <sub>16</sub>	SSN 520	22220-CK	60600	HA 320	2	180/12.1	3 <sup>1</sup> / <sub>2</sub>	HE 320	3 <sup>5</sup> / <sub>8</sub>	HS 320	90	H 320
3 <sup>1</sup> / <sub>16</sub>	SSN 22522-3 <sup>1</sup> / <sub>16</sub>	SSN 522	22222-CK	79400	HA 322	2	200/13.5	4	HE 322	3 <sup>7</sup> / <sub>8</sub>	HS 322	100	H 322
4 <sup>3</sup> / <sub>16</sub>	SSN 22524-4 <sup>3</sup> / <sub>16</sub>	SSN 524	22224-CK	91500	HA 3124	2	215/14	4 <sup>1</sup> / <sub>4</sub>	HE 3124			110	H 3124
4 <sup>7</sup> / <sub>16</sub>	SSN 22526-4 <sup>7</sup> / <sub>16</sub>	SSN 526	22226-CK	108000	HA 3126	2	230/13	4 <sup>1</sup> / <sub>2</sub>	HE 3126			115	H 3126
4 <sup>1</sup> / <sub>16</sub>	SSN 22528-4 <sup>1</sup> / <sub>16</sub>	SSN 528	22228-CK	121300	HA 3128	2	250/15	5	HE 3128			125	H 3128
5 <sup>3</sup> / <sub>16</sub>	SSN 22530-5 <sup>3</sup> / <sub>16</sub>	SSN 530	22230-CK	144000	HA 3130	2	270/16.5	5 <sup>1</sup> / <sub>4</sub>	HE 3130			135	H 3130
5 <sup>7</sup> / <sub>16</sub>	SSN 22532-5 <sup>7</sup> / <sub>16</sub>	SSN 532	22232-CK	160600	HA 3132	2	290/17	5 <sup>1</sup> / <sub>2</sub>	HE 3132			140	H 3132

# ringball bearings Ltd.



**RBL**  
**SPLIT HOUSINGS**

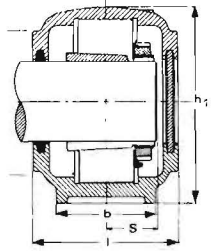
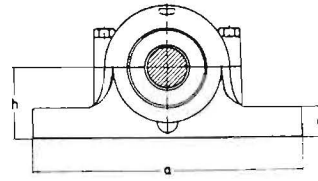
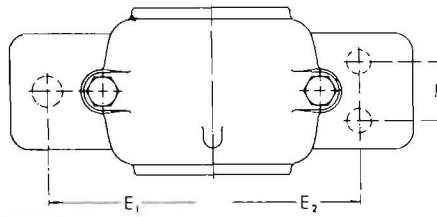

SERIES

**SSN 500**

ALSO AVAILABLE IN  
DUCTILE IRON — SEE PAGE 12

Housing number	h inch	a inch	l inch	b inch	c inch	h <sub>1</sub> inch	2) s inch	Two-Bolt 1) Mounting		Four-Bolt 1) Mounting		
								E <sub>1</sub>	Bolts	E <sub>2</sub>	F	Bolts
SSN 511	2.756	10	3 <sup>3</sup> / <sub>4</sub>	2 <sup>3</sup> / <sub>4</sub>	1 <sup>1</sup> / <sub>8</sub>	5 <sup>1</sup> / <sub>8</sub>	1	8 <sup>1</sup> / <sub>4</sub>	5 <sup>5</sup> / <sub>8</sub>	8	1 <sup>3</sup> / <sub>8</sub>	1 <sup>1</sup> / <sub>2</sub>
SSN 513	3.150	10 <sup>7</sup> / <sub>8</sub>	4 <sup>3</sup> / <sub>8</sub>	3 <sup>1</sup> / <sub>8</sub>	1 <sup>1</sup> / <sub>8</sub>	5 <sup>7</sup> / <sub>8</sub>	1 <sup>3</sup> / <sub>16</sub>	9	5 <sup>5</sup> / <sub>8</sub>	8 <sup>3</sup> / <sub>4</sub>	1 <sup>9</sup> / <sub>16</sub>	1 <sup>1</sup> / <sub>2</sub>
SSN 515	3.150	11	4 <sup>5</sup> / <sub>8</sub>	3 <sup>1</sup> / <sub>8</sub>	1 <sup>1</sup> / <sub>8</sub>	6 <sup>1</sup> / <sub>8</sub>	1 <sup>1</sup> / <sub>4</sub>	9	5 <sup>5</sup> / <sub>8</sub>	8 <sup>3</sup> / <sub>4</sub>	1 <sup>9</sup> / <sub>16</sub>	1 <sup>1</sup> / <sub>2</sub>
SSN 516	3.740	12 <sup>3</sup> / <sub>8</sub>	4 <sup>1</sup> / <sub>2</sub>	3 <sup>5</sup> / <sub>8</sub>	1 <sup>1</sup> / <sub>4</sub>	6 <sup>7</sup> / <sub>8</sub>	1 <sup>5</sup> / <sub>16</sub>	10 <sup>1</sup> / <sub>4</sub>	3 <sup>3</sup> / <sub>4</sub>	10	2	1 <sup>1</sup> / <sub>2</sub>
SSN 517	3.740	12 <sup>5</sup> / <sub>8</sub>	5	3 <sup>5</sup> / <sub>8</sub>	1 <sup>1</sup> / <sub>4</sub>	7 <sup>3</sup> / <sub>8</sub>	1 <sup>7</sup> / <sub>16</sub>	10 <sup>1</sup> / <sub>4</sub>	3 <sup>3</sup> / <sub>4</sub>	10	2	1 <sup>1</sup> / <sub>2</sub>
SSN 518	3.937	13 <sup>3</sup> / <sub>8</sub>	5 <sup>3</sup> / <sub>4</sub>	4	1 <sup>3</sup> / <sub>8</sub>	7 <sup>3</sup> / <sub>4</sub>	1 <sup>9</sup> / <sub>16</sub>	11 <sup>3</sup> / <sub>8</sub>	3 <sup>3</sup> / <sub>4</sub>	11	2	5 <sup>5</sup> / <sub>8</sub>
SSN 520	4.409	15	6 <sup>3</sup> / <sub>8</sub>	4 <sup>3</sup> / <sub>8</sub>	1 <sup>1</sup> / <sub>2</sub>	8 <sup>1</sup> / <sub>2</sub>	1 <sup>15</sup> / <sub>16</sub>	12 <sup>5</sup> / <sub>8</sub>	7 <sup>7</sup> / <sub>8</sub>	11 <sup>3</sup> / <sub>4</sub>	2 <sup>3</sup> / <sub>8</sub>	5 <sup>5</sup> / <sub>8</sub>
SSN 522	4.921	16 <sup>1</sup> / <sub>8</sub>	6 <sup>7</sup> / <sub>8</sub>	4 <sup>3</sup> / <sub>4</sub>	1 <sup>3</sup> / <sub>4</sub>	9 <sup>1</sup> / <sub>2</sub>	2 <sup>1</sup> / <sub>16</sub>	13 <sup>3</sup> / <sub>4</sub>	7 <sup>7</sup> / <sub>8</sub>	12 <sup>3</sup> / <sub>4</sub>	2 <sup>3</sup> / <sub>4</sub>	5 <sup>5</sup> / <sub>8</sub>

**RBL** SPLIT HOUSINGS

SERIES

**SSN 500**

ALSO AVAILABLE IN  
DUCTILE IRON — SEE PAGE 12

Housing number	h inch	a inch	l inch	b inch	c inch	h <sub>1</sub> inch	2) s inch	Two-Bolt 1) Mounting		Four-Bolt 1) Mounting		
								E <sub>1</sub>	Bolts	E <sub>2</sub>	F	Bolts
SSN 511	2.756	10	3 <sup>3</sup> / <sub>4</sub>	2 <sup>3</sup> / <sub>4</sub>	1 <sup>1</sup> / <sub>8</sub>	5 <sup>1</sup> / <sub>8</sub>	1	8 <sup>1</sup> / <sub>4</sub>	5 <sup>5</sup> / <sub>8</sub>	8	1 <sup>3</sup> / <sub>8</sub>	1 <sup>1</sup> / <sub>2</sub>
SSN 513	3.150	10 <sup>7</sup> / <sub>8</sub>	4 <sup>3</sup> / <sub>8</sub>	3 <sup>1</sup> / <sub>8</sub>	1 <sup>1</sup> / <sub>8</sub>	5 <sup>7</sup> / <sub>8</sub>	1 <sup>3</sup> / <sub>16</sub>	9	5 <sup>5</sup> / <sub>8</sub>	8 <sup>3</sup> / <sub>4</sub>	1 <sup>9</sup> / <sub>16</sub>	1 <sup>1</sup> / <sub>2</sub>
SSN 515	3.150	11	4 <sup>5</sup> / <sub>8</sub>	3 <sup>1</sup> / <sub>8</sub>	1 <sup>1</sup> / <sub>8</sub>	6 <sup>1</sup> / <sub>8</sub>	1 <sup>1</sup> / <sub>4</sub>	9	5 <sup>5</sup> / <sub>8</sub>	8 <sup>3</sup> / <sub>4</sub>	1 <sup>9</sup> / <sub>16</sub>	1 <sup>1</sup> / <sub>2</sub>
SSN 516	3.740	12 <sup>3</sup> / <sub>8</sub>	4 <sup>1</sup> / <sub>2</sub>	3 <sup>5</sup> / <sub>8</sub>	1 <sup>1</sup> / <sub>4</sub>	6 <sup>7</sup> / <sub>8</sub>	1 <sup>5</sup> / <sub>16</sub>	10 <sup>1</sup> / <sub>4</sub>	3 <sup>3</sup> / <sub>4</sub>	10	2	1 <sup>1</sup> / <sub>2</sub>
SSN 517	3.740	12 <sup>5</sup> / <sub>8</sub>	5	3 <sup>5</sup> / <sub>8</sub>	1 <sup>1</sup> / <sub>4</sub>	7 <sup>3</sup> / <sub>8</sub>	1 <sup>7</sup> / <sub>16</sub>	10 <sup>1</sup> / <sub>4</sub>	3 <sup>3</sup> / <sub>4</sub>	10	2	1 <sup>1</sup> / <sub>2</sub>
SSN 518	3.937	13 <sup>3</sup> / <sub>8</sub>	5 <sup>3</sup> / <sub>4</sub>	4	1 <sup>3</sup> / <sub>8</sub>	7 <sup>3</sup> / <sub>4</sub>	1 <sup>9</sup> / <sub>16</sub>	11 <sup>3</sup> / <sub>8</sub>	3 <sup>3</sup> / <sub>4</sub>	11	2	5 <sup>5</sup> / <sub>8</sub>
SSN 520	4.409	15	6 <sup>3</sup> / <sub>8</sub>	4 <sup>3</sup> / <sub>8</sub>	1 <sup>1</sup> / <sub>2</sub>	8 <sup>1</sup> / <sub>2</sub>	1 <sup>15</sup> / <sub>16</sub>	12 <sup>5</sup> / <sub>8</sub>	7 <sup>7</sup> / <sub>8</sub>	11 <sup>3</sup> / <sub>4</sub>	2 <sup>3</sup> / <sub>8</sub>	5 <sup>5</sup> / <sub>8</sub>
SSN 522	4.921	16 <sup>1</sup> / <sub>8</sub>	6 <sup>7</sup> / <sub>8</sub>	4 <sup>3</sup> / <sub>4</sub>	1 <sup>3</sup> / <sub>4</sub>	9 <sup>1</sup> / <sub>2</sub>	2 <sup>1</sup> / <sub>16</sub>	13 <sup>3</sup> / <sub>4</sub>	7 <sup>7</sup> / <sub>8</sub>	12 <sup>3</sup> / <sub>4</sub>	2 <sup>3</sup> / <sub>4</sub>	5 <sup>5</sup> / <sub>8</sub>
SSN 524	5.512	16 <sup>1</sup> / <sub>8</sub>	7 <sup>3</sup> / <sub>8</sub>	4 <sup>3</sup> / <sub>4</sub>	1 <sup>3</sup> / <sub>4</sub>	10 <sup>5</sup> / <sub>8</sub>	2 <sup>1</sup> / <sub>4</sub>	13 <sup>3</sup> / <sub>4</sub>	7 <sup>7</sup> / <sub>8</sub>	13	2 <sup>3</sup> / <sub>4</sub>	5 <sup>5</sup> / <sub>8</sub>
SSN 526	5.906	17 <sup>1</sup> / <sub>2</sub>	7 <sup>1</sup> / <sub>2</sub>	5 <sup>1</sup> / <sub>8</sub>	2	11 <sup>1</sup> / <sub>2</sub>	2 <sup>7</sup> / <sub>16</sub>	15	1	14 <sup>1</sup> / <sub>2</sub>	2 <sup>3</sup> / <sub>4</sub>	3 <sup>3</sup> / <sub>4</sub>
SSN 528	5.906	19 <sup>3</sup> / <sub>4</sub>	8 <sup>1</sup> / <sub>8</sub>	5 <sup>1</sup> / <sub>8</sub>	2	12	2 <sup>1</sup> / <sub>2</sub>	16 <sup>1</sup> / <sub>2</sub>	1 <sup>1</sup> / <sub>4</sub>	15 <sup>3</sup> / <sub>4</sub>	3 <sup>1</sup> / <sub>8</sub>	7 <sup>7</sup> / <sub>8</sub>
SSN 530	6.299	20 <sup>7</sup> / <sub>8</sub>	8 <sup>5</sup> / <sub>8</sub>	6 <sup>3</sup> / <sub>8</sub>	2 <sup>3</sup> / <sub>8</sub>	12 <sup>3</sup> / <sub>4</sub>	2 <sup>3</sup> / <sub>4</sub>	17 <sup>3</sup> / <sub>4</sub>	1 <sup>1</sup> / <sub>4</sub>	17	3 <sup>3</sup> / <sub>8</sub>	7 <sup>7</sup> / <sub>8</sub>
SSN 532	6.693	21 <sup>5</sup> / <sub>8</sub>	9 <sup>1</sup> / <sub>4</sub>	6 <sup>3</sup> / <sub>8</sub>	2 <sup>3</sup> / <sub>8</sub>	13 <sup>5</sup> / <sub>8</sub>	3	18 <sup>1</sup> / <sub>2</sub>	1 <sup>1</sup> / <sub>4</sub>	17 <sup>3</sup> / <sub>4</sub>	3 <sup>1</sup> / <sub>2</sub>	7 <sup>7</sup> / <sub>8</sub>

1) Housings are supplied without mounting bolt holes.

2) The maximum permissible shaft length from centreline of housing when one end closed.

# ringball bearings ltd.

## RBL SPLIT HOUSING PILLOW BLOCKS for self-aligning ball bearings with adapter sleeves

SERIES

**SSN 1500-D**

**Ductile Iron**

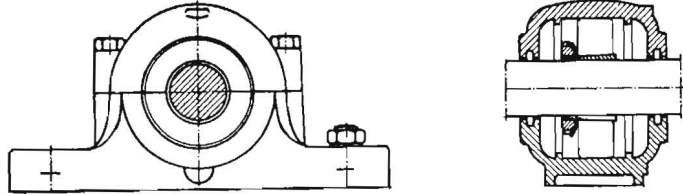

### SOLID BASE - SUITABLE FOR 2 or 4 BOLT DRILLING

Standard Shaft dia. inch	Complete Pillow Block number	COMPONENT PART NUMBERS						Alternative Shaft Sizes					
		Housing number	Bearing		Adapter Sleeve number	Fixing Rings (No. req'd.)		dia. inch	Adapter number	dia. inch	Adapter number	dia. mm	Adapter number
			Bearing number	Dyn. Load Rtg. Lbs.									
1 <sup>5</sup> / <sub>16</sub>	SSN 1511-D-1 <sup>5</sup> / <sub>16</sub>	SSN 511-D	1211-K	4600	HA 211	2	100/6	2	HE 211	1 <sup>7</sup> / <sub>8</sub>	HS 211	50	H 211
2 <sup>3</sup> / <sub>16</sub>	SSN 1513-D-2 <sup>3</sup> / <sub>16</sub>	SSN 513-D	1213-K	5300	HA 213	2	120/10	2 <sup>1</sup> / <sub>4</sub>	HE 213	2 <sup>3</sup> / <sub>8</sub>	HS 213	60	H 213
2 <sup>7</sup> / <sub>16</sub>	SSN 1515-D-2 <sup>7</sup> / <sub>16</sub>	SSN 515-D	1215-K	6700	HA 215	2	130/8	2 <sup>1</sup> / <sub>2</sub>	HE 215			65	H 215
2 <sup>15</sup> / <sub>16</sub>	SSN 1517-D-2 <sup>15</sup> / <sub>16</sub>	SSN 517-D	1217-K	8400	HA 217	2	150/9	3	HE 217	2 <sup>7</sup> / <sub>8</sub>	HS 217	75	H 217
3 <sup>7</sup> / <sub>16</sub>	SSN 1520-D-3 <sup>7</sup> / <sub>16</sub>	SSN 520-D	1220-K	11900	HA 220	2	180/12	3 <sup>1</sup> / <sub>2</sub>	HE 220			90	H 220
3 <sup>15</sup> / <sub>16</sub>	SSN 1522-D-3 <sup>15</sup> / <sub>16</sub>	SSN 522-D	1222-K	15000	HA 222	1	200/15	4	HE 222	3 <sup>7</sup> / <sub>8</sub>	HS 222	100	H 222

## RBL SPLIT HOUSING PILLOW BLOCKS for spherical roller bearings with adapter sleeves

SERIES

**SSN 22500-D**

**Ductile Iron**

### SOLID BASE - SUITABLE FOR 2 or 4 BOLT DRILLING

Standard Shaft dia. inch	Complete Pillow Block number	COMPONENT PART NUMBERS						Alternative Shaft Sizes					
		Housing number	Bearing		Adapter Sleeve number	Fixing Rings (No. req'd.)		dia. inch	Adapter number	dia. inch	Adapter number	dia. mm	Adapter number
			Bearing number	Dyn. Load Rtg. Lbs.									
1 <sup>5</sup> / <sub>16</sub>	SSN 22511-D-1 <sup>5</sup> / <sub>16</sub>	SSN 511-D	22211-CK	18800	HA 311	1	100/8	2	HE 311	1 <sup>7</sup> / <sub>8</sub>	HS 311	50	H 311
2 <sup>3</sup> / <sub>16</sub>	SSN 22513-D-2 <sup>3</sup> / <sub>16</sub>	SSN 513-D	22213-CK	26900	HA 313	1	120/12	2 <sup>1</sup> / <sub>4</sub>	HE 313	2 <sup>3</sup> / <sub>8</sub>	HS 313	60	H 313
2 <sup>7</sup> / <sub>16</sub>	SSN 22515-D-2 <sup>7</sup> / <sub>16</sub>	SSN 515-D	22215-CK	30200	HA 315	1	130/10	2 <sup>1</sup> / <sub>2</sub>	HE 315			65	H 315
2 <sup>15</sup> / <sub>16</sub>	SSN 22517-D-2 <sup>15</sup> / <sub>16</sub>	SSN 517-D	22217-CK	39700	HA 317	1	150/10	3	HE 317	2 <sup>7</sup> / <sub>8</sub>	HS 317	75	H 317
3 <sup>7</sup> / <sub>16</sub>	SSN 22520-D-3 <sup>7</sup> / <sub>16</sub>	SSN 520-D	22220-CK	60600	HA 320	2	180/12.1	3 <sup>1</sup> / <sub>2</sub>	HE 320	3 <sup>5</sup> / <sub>8</sub>	HS 320	90	H 320
3 <sup>15</sup> / <sub>16</sub>	SSN 22522-D-3 <sup>15</sup> / <sub>16</sub>	SSN 522-D	22222-CK	79400	HA 322	2	200/13.5	4	HE 322	3 <sup>7</sup> / <sub>8</sub>	HS 322	100	H 322
4 <sup>3</sup> / <sub>16</sub>	SSN 22524-D-4 <sup>3</sup> / <sub>16</sub>	SSN 524-D	22224-CK	91500	HA 3124	2	215/14	4 <sup>1</sup> / <sub>4</sub>	HE 3124			110	H 3124
4 <sup>7</sup> / <sub>16</sub>	SSN 22526-D-4 <sup>7</sup> / <sub>16</sub>	SSN 526-D	22226-CK	108000	HA 326	2	230/13	4 <sup>1</sup> / <sub>2</sub>	HE 3126			115	H 3126
4 <sup>15</sup> / <sub>16</sub>	SSN 22528-D-4 <sup>15</sup> / <sub>16</sub>	SSN 528-D	22228-CK	121300	HA 3128	2	250/15	5	HE 3128			125	H 3128
5 <sup>3</sup> / <sub>16</sub>	SSN 22530-D-5 <sup>3</sup> / <sub>16</sub>	SSN 530-D	22230-CK	144100	HA 3130	2	270/16.5	5 <sup>1</sup> / <sub>4</sub>	HE 3130			135	H 3130
5 <sup>7</sup> / <sub>16</sub>	SSN 22532-D-5 <sup>7</sup> / <sub>16</sub>	SSN 532-D	22232-CK	170000	HA 3132	2	290/17	5 <sup>1</sup> / <sub>2</sub>	HE 3132			140	H 3132

THE SSND DUCTILE IRON SERIES SUPERSEDES OUR SSN-G83 DUCTILE SERIES

# ringball bearings ltd.

**RBL**  
SPLIT HOUSINGS

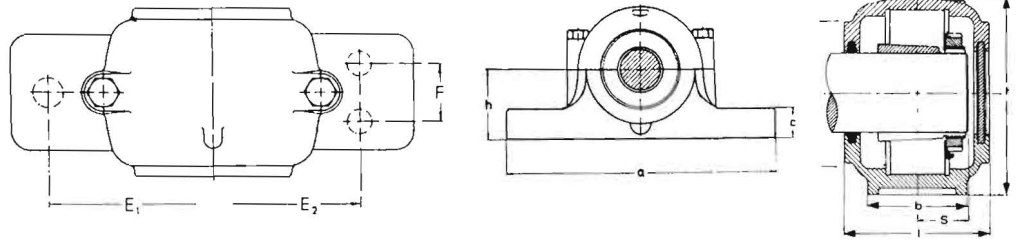

**SSN 500-D**

**Ductile Iron**

Housing number	For Shaft Sizes inch			h inch	a inch	l inch	b inch	c inch	h <sub>1</sub> inch	2) s inch	Two-Bolt 1) Mounting		Four-Bolt 1) Mounting		
											E <sub>1</sub>	Bolts	E <sub>2</sub>	F	Bolts
SSN 511-D	1 <sup>5</sup> / <sub>16</sub>	2		2.756	10	3 <sup>3</sup> / <sub>4</sub>	2 <sup>3</sup> / <sub>4</sub>	1 <sup>1</sup> / <sub>8</sub>	5 <sup>5</sup> / <sub>8</sub>	1	8 <sup>1</sup> / <sub>4</sub>	5 <sup>5</sup> / <sub>8</sub>	8	1 <sup>3</sup> / <sub>8</sub>	1 <sup>1</sup> / <sub>2</sub>
SSN 513-D	2 <sup>3</sup> / <sub>16</sub>	2 <sup>1</sup> / <sub>4</sub>	2 <sup>3</sup> / <sub>8</sub>	3.150	10 <sup>7</sup> / <sub>8</sub>	4 <sup>3</sup> / <sub>8</sub>	3 <sup>1</sup> / <sub>8</sub>	1 <sup>1</sup> / <sub>8</sub>	5 <sup>5</sup> / <sub>8</sub>	1 <sup>3</sup> / <sub>16</sub>	9	5 <sup>5</sup> / <sub>8</sub>	8 <sup>3</sup> / <sub>4</sub>	1 <sup>9</sup> / <sub>16</sub>	1 <sup>1</sup> / <sub>2</sub>
SSN 515-D	2 <sup>7</sup> / <sub>16</sub>	2 <sup>1</sup> / <sub>2</sub>		3.150	11	4 <sup>5</sup> / <sub>8</sub>	3 <sup>3</sup> / <sub>8</sub>	1 <sup>1</sup> / <sub>8</sub>	6 <sup>1</sup> / <sub>8</sub>	1 <sup>1</sup> / <sub>4</sub>	9	5 <sup>5</sup> / <sub>8</sub>	8 <sup>3</sup> / <sub>4</sub>	1 <sup>9</sup> / <sub>16</sub>	1 <sup>1</sup> / <sub>2</sub>
SSN 517-D	2 <sup>15</sup> / <sub>16</sub>	3		3.740	12 <sup>5</sup> / <sub>8</sub>	5	3 <sup>5</sup> / <sub>8</sub>	1 <sup>1</sup> / <sub>4</sub>	7 <sup>3</sup> / <sub>8</sub>	1 <sup>7</sup> / <sub>16</sub>	10 <sup>1</sup> / <sub>4</sub>	3 <sup>3</sup> / <sub>4</sub>	10	2	1 <sup>1</sup> / <sub>2</sub>
SSN 520-D	3 <sup>7</sup> / <sub>16</sub>	3 <sup>1</sup> / <sub>2</sub>		4.409	15	6 <sup>3</sup> / <sub>8</sub>	4 <sup>3</sup> / <sub>8</sub>	1 <sup>1</sup> / <sub>2</sub>	8 <sup>1</sup> / <sub>2</sub>	1 <sup>15</sup> / <sub>16</sub>	12 <sup>5</sup> / <sub>8</sub>	7 <sup>7</sup> / <sub>8</sub>	11 <sup>3</sup> / <sub>4</sub>	2 <sup>3</sup> / <sub>8</sub>	5 <sup>5</sup> / <sub>8</sub>
SSN 522-D	3 <sup>15</sup> / <sub>16</sub>	4	3 <sup>7</sup> / <sub>8</sub>	4.921	16 <sup>1</sup> / <sub>8</sub>	6 <sup>7</sup> / <sub>8</sub>	4 <sup>3</sup> / <sub>4</sub>	1 <sup>3</sup> / <sub>4</sub>	9 <sup>1</sup> / <sub>2</sub>	2 <sup>1</sup> / <sub>16</sub>	13 <sup>3</sup> / <sub>4</sub>	7 <sup>7</sup> / <sub>8</sub>	12 <sup>3</sup> / <sub>4</sub>	2 <sup>3</sup> / <sub>4</sub>	5 <sup>5</sup> / <sub>8</sub>

**RBL** SPLIT HOUSINGS

**SSN 500-D**

**Ductile Iron**

Housing Number	For Shaft Sizes inch			h inch	a inch	l inch	b inch	c inch	h <sub>1</sub> inch	2) s inch	Two-Bolt 1) Mounting		Four-Bolt 1) Mounting		
											E <sub>1</sub>	Bolts	E <sub>2</sub>	F	Bolts
SSN 511-D	1 <sup>5</sup> / <sub>16</sub>	2		2.756	10	3 <sup>3</sup> / <sub>4</sub>	2 <sup>3</sup> / <sub>4</sub>	1 <sup>1</sup> / <sub>8</sub>	5 <sup>5</sup> / <sub>8</sub>	1	8 <sup>1</sup> / <sub>4</sub>	5 <sup>5</sup> / <sub>8</sub>	8	1 <sup>3</sup> / <sub>8</sub>	1 <sup>1</sup> / <sub>2</sub>
SSN 513-D	2 <sup>3</sup> / <sub>16</sub>	2 <sup>1</sup> / <sub>4</sub>	2 <sup>3</sup> / <sub>8</sub>	3.150	10 <sup>7</sup> / <sub>8</sub>	4 <sup>3</sup> / <sub>8</sub>	3 <sup>1</sup> / <sub>8</sub>	1 <sup>1</sup> / <sub>8</sub>	5 <sup>5</sup> / <sub>8</sub>	1 <sup>3</sup> / <sub>16</sub>	9	5 <sup>5</sup> / <sub>8</sub>	8 <sup>3</sup> / <sub>4</sub>	1 <sup>9</sup> / <sub>16</sub>	1 <sup>1</sup> / <sub>2</sub>
SSN 515-D	2 <sup>7</sup> / <sub>16</sub>	2 <sup>1</sup> / <sub>2</sub>		3.150	11	4 <sup>5</sup> / <sub>8</sub>	3 <sup>3</sup> / <sub>8</sub>	1 <sup>1</sup> / <sub>8</sub>	6 <sup>1</sup> / <sub>8</sub>	1 <sup>1</sup> / <sub>4</sub>	9	5 <sup>5</sup> / <sub>8</sub>	8 <sup>3</sup> / <sub>4</sub>	1 <sup>9</sup> / <sub>16</sub>	1 <sup>1</sup> / <sub>2</sub>
SSN 517-D	2 <sup>15</sup> / <sub>16</sub>	3		3.740	12 <sup>5</sup> / <sub>8</sub>	5	3 <sup>5</sup> / <sub>8</sub>	1 <sup>1</sup> / <sub>4</sub>	7 <sup>3</sup> / <sub>8</sub>	1 <sup>7</sup> / <sub>16</sub>	10 <sup>1</sup> / <sub>4</sub>	3 <sup>3</sup> / <sub>4</sub>	10	2	1 <sup>1</sup> / <sub>2</sub>
SSN 520-D	3 <sup>7</sup> / <sub>16</sub>	3 <sup>1</sup> / <sub>2</sub>		4.409	15	6 <sup>3</sup> / <sub>8</sub>	4 <sup>3</sup> / <sub>8</sub>	1 <sup>1</sup> / <sub>2</sub>	8 <sup>1</sup> / <sub>2</sub>	1 <sup>15</sup> / <sub>16</sub>	12 <sup>5</sup> / <sub>8</sub>	7 <sup>7</sup> / <sub>8</sub>	11 <sup>3</sup> / <sub>4</sub>	2 <sup>3</sup> / <sub>8</sub>	5 <sup>5</sup> / <sub>8</sub>
SSN 522-D	3 <sup>15</sup> / <sub>16</sub>	4	3 <sup>7</sup> / <sub>8</sub>	4.921	16 <sup>1</sup> / <sub>8</sub>	6 <sup>7</sup> / <sub>8</sub>	4 <sup>3</sup> / <sub>4</sub>	1 <sup>3</sup> / <sub>4</sub>	9 <sup>1</sup> / <sub>2</sub>	2 <sup>1</sup> / <sub>16</sub>	13 <sup>3</sup> / <sub>4</sub>	7 <sup>7</sup> / <sub>8</sub>	12 <sup>3</sup> / <sub>4</sub>	2 <sup>3</sup> / <sub>4</sub>	5 <sup>5</sup> / <sub>8</sub>
SSN 524-D	4 <sup>3</sup> / <sub>16</sub>	4 <sup>1</sup> / <sub>4</sub>		5.512	16 <sup>1</sup> / <sub>8</sub>	7 <sup>3</sup> / <sub>8</sub>	4 <sup>3</sup> / <sub>4</sub>	1 <sup>3</sup> / <sub>4</sub>	10 <sup>5</sup> / <sub>8</sub>	2 <sup>1</sup> / <sub>4</sub>	13 <sup>3</sup> / <sub>4</sub>	7 <sup>7</sup> / <sub>8</sub>	13	2 <sup>3</sup> / <sub>4</sub>	5 <sup>5</sup> / <sub>8</sub>
SSN 526-D	4 <sup>7</sup> / <sub>16</sub>	4 <sup>1</sup> / <sub>2</sub>		5.906	17 <sup>1</sup> / <sub>2</sub>	7 <sup>1</sup> / <sub>2</sub>	5 <sup>5</sup> / <sub>8</sub>	2	11 <sup>1</sup> / <sub>2</sub>	2 <sup>7</sup> / <sub>16</sub>	15	1	14 <sup>1</sup> / <sub>2</sub>	2 <sup>3</sup> / <sub>4</sub>	3 <sup>3</sup> / <sub>4</sub>
SSN 528-D	4 <sup>15</sup> / <sub>16</sub>	5		5.906	19 <sup>3</sup> / <sub>4</sub>	8 <sup>1</sup> / <sub>8</sub>	5 <sup>7</sup> / <sub>8</sub>	2	12	2 <sup>1</sup> / <sub>2</sub>	16 <sup>1</sup> / <sub>2</sub>	1 <sup>1</sup> / <sub>4</sub>	15 <sup>3</sup> / <sub>4</sub>	3 <sup>1</sup> / <sub>8</sub>	7 <sup>7</sup> / <sub>8</sub>
SSN 530-D	5 <sup>3</sup> / <sub>16</sub>	5 <sup>1</sup> / <sub>4</sub>		6.299	20 <sup>7</sup> / <sub>8</sub>	8 <sup>5</sup> / <sub>8</sub>	6 <sup>3</sup> / <sub>8</sub>	2 <sup>3</sup> / <sub>8</sub>	12 <sup>3</sup> / <sub>4</sub>	2 <sup>3</sup> / <sub>4</sub>	17 <sup>3</sup> / <sub>4</sub>	1 <sup>1</sup> / <sub>4</sub>	17	3 <sup>5</sup> / <sub>8</sub>	7 <sup>7</sup> / <sub>8</sub>
SSN 532-D	5 <sup>7</sup> / <sub>16</sub>	5 <sup>1</sup> / <sub>2</sub>		6.693	21 <sup>5</sup> / <sub>8</sub>	9 <sup>1</sup> / <sub>4</sub>	6 <sup>3</sup> / <sub>8</sub>	2 <sup>3</sup> / <sub>8</sub>	13 <sup>3</sup> / <sub>8</sub>	3	18 <sup>1</sup> / <sub>2</sub>	1 <sup>1</sup> / <sub>4</sub>	17 <sup>3</sup> / <sub>4</sub>	3 <sup>1</sup> / <sub>2</sub>	7 <sup>7</sup> / <sub>8</sub>

1) Housings are supplied without mounting bolt holes.

2) The maximum permissible shaft length from centreline of housing when one end closed.

# ringball bearings ltd.

## RBL SPLIT HOUSING PILLOW BLOCKS for self-aligning ball bearings with adapter sleeves

SERIES **SAF 1500**

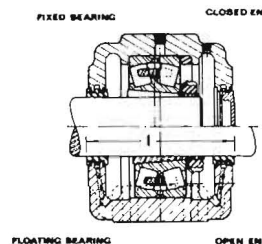
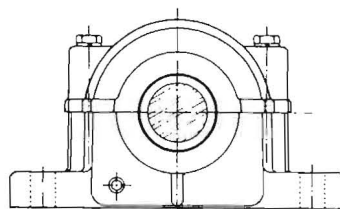

**CAST IRON - 2 or 4 BOLT** ALSO AVAILABLE IN CAST STEEL — SPECIFY 'SAFS'

Standard Shaft dia. inch	Complete Pillow Block number	COMPONENT PART NUMBERS						Alternative Shaft Sizes *			
		Housing number	Bearing		Adapter Sleeve number	Triple Seal Rings (2 each)	Fixing Rings (No. req'd.)	dia. inch	Adapter number	dia. inch	Adapter number
			Bearing number	Dyn. Load Rtg. Lbs.							
1 <sup>7</sup> / <sub>16</sub>	SAF 1509-1 <sup>7</sup> / <sub>16</sub>	SAF 509	1209-K	3800	HA 209	LER 17	1 SR-9-0	1 <sup>1</sup> / <sub>2</sub>	HE 209		
1 <sup>1</sup> / <sub>2</sub>	SAF 1510-1 <sup>1</sup> / <sub>2</sub>	SAF 510	1210-K	3900	HA 210	LER 20	1 SR-10-8	1 <sup>3</sup> / <sub>4</sub>	HE 210	1 <sup>5</sup> / <sub>8</sub>	HS 210
1 <sup>5</sup> / <sub>16</sub>	SAF 1511-1 <sup>5</sup> / <sub>16</sub>	SAF 511	1211-K	4600	HA 211	LER 24	1 SR-11-9	2	HE 211	1 <sup>7</sup> / <sub>8</sub>	HS 211
2 <sup>3</sup> / <sub>16</sub>	SAF 1513-2 <sup>3</sup> / <sub>16</sub>	SAF 513	1213-K	5300	HA 213	LER 29	2 SR-13-0	2 <sup>1</sup> / <sub>4</sub>	HE 213	2 <sup>3</sup> / <sub>8</sub>	HS 213
2 <sup>7</sup> / <sub>16</sub>	SAF 1515-2 <sup>7</sup> / <sub>16</sub>	SAF 515	1215-K	6700	HA 215	LER 37	2 SR-15-0	2 <sup>1</sup> / <sub>2</sub>	HE 215		
2 <sup>1</sup> / <sub>2</sub>	SAF 1516-2 <sup>1</sup> / <sub>2</sub>	SAF 516	1216-K	6800	HA 216	LER 44	2 SR-1516	2 <sup>3</sup> / <sub>4</sub>	HE 216		
2 <sup>5</sup> / <sub>16</sub>	SAF 1517-2 <sup>5</sup> / <sub>16</sub>	SAF 517	1217-K	8400	HA 217	LER 53	2 SR-1517	3	HE 217	2 <sup>7</sup> / <sub>8</sub>	HS 217
3 <sup>3</sup> / <sub>16</sub>	SAF 1518-3 <sup>3</sup> / <sub>16</sub>	SAF 518	1218-K	9700	HA 218	LER 188	2 SR-1518				
3 <sup>7</sup> / <sub>16</sub>	SAF 1520-3 <sup>7</sup> / <sub>16</sub>	SAF 520	1220-K	11900	HA 220	LER 102	2 SR-1520	3 <sup>1</sup> / <sub>2</sub>	HE 220		
3 <sup>5</sup> / <sub>16</sub>	SAF 1522-3 <sup>5</sup> / <sub>16</sub>	SAF 522	1222-K	15000	HA 222	LER 109	2 SR-1522	4	HE 222	3 <sup>7</sup> / <sub>8</sub>	HS 222

SERIES **SAF 1600**

**CAST IRON - 2 or 4 BOLT** ALSO AVAILABLE IN CAST STEEL — SPECIFY 'SAFS'

Standard Shaft dia. inch	Complete Pillow Block number	COMPONENT PART NUMBERS						Alternative Shaft Sizes *			
		Housing number	Bearing		Adapter Sleeve number	Triple Seal Rings (2 each)	Fixing Rings (No. req'd.)	dia. inch	Adapter number	dia. inch	Adapter number
			Bearing number	Dyn. Load Rtg. Lbs.							
1 <sup>7</sup> / <sub>16</sub>	SAF 1609-1 <sup>7</sup> / <sub>16</sub>	SAF 609	1309-K	6600	HA 309	LER 17	2 SR-1609	1 <sup>1</sup> / <sub>2</sub>	HE 309		
1 <sup>1</sup> / <sub>2</sub>	SAF 1610-1 <sup>1</sup> / <sub>2</sub>	SAF 610	1310-K	7500	HA 310	LER 20	2 SR-1610	1 <sup>3</sup> / <sub>4</sub>	HE 310		
1 <sup>5</sup> / <sub>16</sub>	SAF 1611-1 <sup>5</sup> / <sub>16</sub>	SAF 611	1311-K	8800	HA 311	LER 24	2 SR-1611	2	HE 311	1 <sup>7</sup> / <sub>8</sub>	HS 311
2 <sup>3</sup> / <sub>16</sub>	SAF 1613-2 <sup>3</sup> / <sub>16</sub>	SAF 613	1313-K	10600	HA 313	LER 32	2 SR-1613	2 <sup>1</sup> / <sub>4</sub>	HE 313	2 <sup>3</sup> / <sub>8</sub>	HS 313
2 <sup>7</sup> / <sub>16</sub>	SAF 1615-2 <sup>7</sup> / <sub>16</sub>	SAF 615	1315-K	13700	HA 315	LER 37	2 SR-1615	2 <sup>1</sup> / <sub>2</sub>	HE 315		
2 <sup>1</sup> / <sub>2</sub>	SAF 1616-2 <sup>1</sup> / <sub>2</sub>	SAF 616	1316-K	15300	HA 316	LER 44	2 SR-1616	2 <sup>3</sup> / <sub>4</sub>	HE 316		
2 <sup>5</sup> / <sub>16</sub>	SAF 1617-2 <sup>5</sup> / <sub>16</sub>	SAF 617	1317-K	16900	HA 317	LER 184	2 SR-1617	3	HE 317	2 <sup>7</sup> / <sub>8</sub>	HS 317
3 <sup>3</sup> / <sub>16</sub>	SAF 1618-3 <sup>3</sup> / <sub>16</sub>	SAF 618	1318-K	20100	HA 318	LER 188	2 SR-1618	3 <sup>1</sup> / <sub>4</sub>	HE 318	3 <sup>1</sup> / <sub>8</sub>	HS 318
3 <sup>7</sup> / <sub>16</sub>	SAF 1620-3 <sup>7</sup> / <sub>16</sub>	SAF 620	1320-K	24700	HA 320	LER 102	2 SR-1620	3 <sup>1</sup> / <sub>2</sub>	HE 320	3 <sup>5</sup> / <sub>8</sub>	HS 320
3 <sup>5</sup> / <sub>16</sub>	SAF 1622-3 <sup>5</sup> / <sub>16</sub>	SAF 622	1322-K	28400	HA 322	LER 109	2 SR-1622	4	HE 322	3 <sup>7</sup> / <sub>8</sub>	HS 322

- (\*) Size of triple seal rings will change with alternative shaft size.
- To obtain proper seal ring clearance for shaft diameter refer to tolerance table, page 27.
- Please order 'Fixing Ring' for fixed bearing. Use only one fixed bearing per shaft.
- Maintain this level for oil Lubrication. Refer to page 24 and page 25 for further information on lubrication.

# ringball bearings Ltd.

## RBL SPLIT HOUSINGS

SERIES

# SAF 500

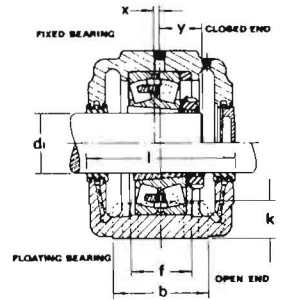
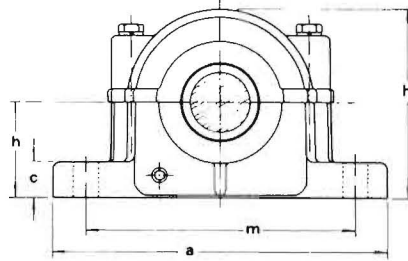

Housing number	h inch	a inch	b inch	c inch	m inch	h <sub>1</sub> inch	l inch	6) k inch	x inch	f inch	Bolt Size Req'd.		For Shaft sizes inch		
											2-bolt	4-bolt			
SAF 509	2 1/4	8 1/4	2 3/8	1 3/16	6 5/8	4 3/8	3 5/8	1	3/16		1/2	—	1 1/16	1 1/2	
SAF 510	2 1/2	8 1/4	2 3/8	1 5/16	6 3/4	4 3/4	3 5/8	1 1/8	3/16		1/2	—	1 1/16	1 3/4	1 5/8
SAF 511	2 3/4	9 5/8	2 3/4	1 5/16	7 5/8	5 1/4	3 7/8	1 1/4	3/16		5/8	—	1 5/16	2	1 7/8
SAF 513	3	11	3 1/8	1	8 13/16	5 15/16	4 1/2	1 1/8	3/16		5/8	1/2	2 3/16	2 1/4	2 3/8
SAF 515	3 1/4	11 1/4	3 1/8	1 1/8	9 1/8	6 3/8	4 3/4	1 1/4	3/16	1 7/8	5/8	1/2	2 7/16	2 1/2	
SAF 516	3 1/2	13	3 1/2	1 3/16	10 5/16	6 7/8	4 7/8	1 11/32	3/16	2 1/8	3/4	5/8	2 11/16	2 3/4	
SAF 517	3 3/4	13	3 1/2	1 1/4	10 7/16	7 9/16	5	1 7/16	3/16	2 1/8	3/4	5/8	2 15/16	3	2 7/8
SAF 518	4	13 3/4	3 7/8	1 5/16	11	7 3/4	5 3/4	1 17/32	3/16	2 1/8	3/4	5/8	3 3/16	3 1/4	
SAF 520	4 1/2	15 1/4	4 3/8	1 1/2	12 3/8	8 11/16	6	1 3/4	3/16	2 3/8	7/8	3/4	3 7/16	3 1/2	
SAF 522	4 15/16	16 1/2	4 3/4	1 5/8	13 9/16	9 9/16	6 1/2	1 7/8	3/16	2 3/4	—	3/4	3 15/16	4	3 7/8

\* Please specify 'FSAF' for Four-Bolt Base, bolt size required shown in brackets.  
Please note that housing sizes SAF 522 and up are supplied with Four-Bolt Base as standard.

SERIES

# SAF 600

Housing number	h inch	a inch	b inch	c inch	m inch	h <sub>1</sub> inch	l inch	6) k inch	x inch	f inch	Bolt Size Req'd.		For Shaft sizes inch		
											2-bolt	4-bolt			
SAF 609	2 3/4	9 5/8	2 3/4	1	7 5/8	5 5/16	4 1/4	1 5/16	3/16		5/8	—	1 7/16	1 1/2	
SAF 610	3	10 5/8	2 3/4	1 1/8	8 3/8	5 13/16	4 5/8	1 3/8	3/16		5/8	—	1 11/16	1 3/4	
SAF 611	3 1/4	11	3 1/8	1 3/16	8 13/16	6 3/16	4 7/8	1 1/2	3/16	2	5/8	1/2	1 5/16	2	1 7/8
SAF 613	3 1/2	13	3 1/2	1 1/4	10 5/16	6 15/16	5 3/8	1 15/32	3/16	2 1/8	3/4	5/8	2 3/16	2 1/4	2 3/8
SAF 615	4	13 3/4	3 7/8	1 5/16	11	7 13/16	6 1/4	1 11/16	3/16	2 1/8	3/4	5/8	2 7/16	2 1/2	
SAF 616	4 1/4	14 1/4	3 7/8	1 5/16	11 5/8	8 1/4	6 1/2	1 3/4	3/16	2 1/8	3/4	5/8	2 11/16	2 3/4	
SAF 617	4 1/2	15 1/4	4 3/8	1 3/4	12 3/8	8 3/4	6 3/4	1 13/16	3/16	2 3/8	7/8	3/4	2 15/16	3	2 7/8
SAF 618	4 3/4	15 1/2	4 3/8	2	12 3/4	9 9/16	6 7/8	2	3/16	2 1/4	—	3/4	3 3/16	3 1/4	3 1/8
SAF 620	5 1/4	16 1/2	4 3/4	2 1/8	13 7/8	10 1/4	7 3/8	2 1/8	3/16	2 3/4	—	3/4	3 7/16	3 1/2	3 5/8
SAF 622	6	18 3/8	5 1/8	2 3/8	15 5/16	11 1/2	8	2 1/2	3/16	3 1/4	—	7/8	3 15/16	4	3 7/8

3. (\*) Please specify 'FSAF' for 4-bolt base.

4. Permissible Radial Load for bearings may be found on page 22 and 23.

# ringball bearings Ltd.

## RBL SPLIT HOUSING PILLOW BLOCKS for spherical roller bearings with adapter sleeves

SERIES

**SAF 22500**

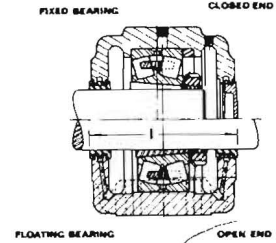
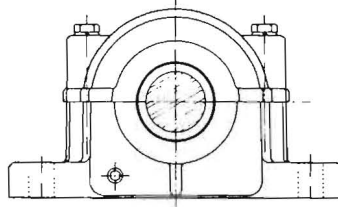

**CAST IRON - 2 or 4 BOLT** ALSO AVAILABLE IN CAST STEEL — SPECIFY 'SAFS'

Standard Shaft dia. inch	Complete Pillow Block number	COMPONENT PART NUMBERS						Alternative Shaft Sizes *			
		Housing number	Bearing		Adapter Sleeve number	Triple Seal Rings (2 each)	Fixing Rings (No. req'd.)	dia. inch	Adapter number	dia. inch	Adapter number
			Bearing number	Dyn. Load Rtg. Lbs.							
1 <sup>1</sup> / <sub>16</sub>	SAF 22509-1 <sup>1</sup> / <sub>16</sub>	SAF 509	22209-CK	14400	HA 309	LER 17	1 SR-9-9	1 <sup>1</sup> / <sub>2</sub>	HE 309		
1 <sup>1</sup> / <sub>16</sub>	SAF 22510-1 <sup>1</sup> / <sub>16</sub>	SAF 510	22210-CK	15700	HA 310	LER 20	1 SR-10-0	1 <sup>3</sup> / <sub>4</sub>	HE 310	1 <sup>1</sup> / <sub>8</sub>	HS 310
1 <sup>1</sup> / <sub>16</sub>	SAF 22511-1 <sup>1</sup> / <sub>16</sub>	SAF 511	22211-CK	18800	HA 311	LER 24	1 SR-11-0	2	HE 311	1 <sup>1</sup> / <sub>8</sub>	HS 311
2 <sup>3</sup> / <sub>16</sub>	SAF 22513-2 <sup>3</sup> / <sub>16</sub>	SAF 513	22213-CK	26900	HA 313	LER 29	1 SR-13-0	2 <sup>1</sup> / <sub>4</sub>	HE 313	2 <sup>3</sup> / <sub>8</sub>	HS 313
2 <sup>7</sup> / <sub>16</sub>	SAF 22515-2 <sup>7</sup> / <sub>16</sub>	SAF 515	22215-CK	30200	HA 315	LER 37	1 SR-15-0	2 <sup>1</sup> / <sub>2</sub>	HE 315		
2 <sup>1</sup> / <sub>16</sub>	SAF 22516-2 <sup>1</sup> / <sub>16</sub>	SAF 516	22216-CK	34400	HA 316	LER 44	1 SR-16-13	2 <sup>3</sup> / <sub>4</sub>	HE 316	2 <sup>7</sup> / <sub>8</sub>	HS 316
2 <sup>1</sup> / <sub>16</sub>	SAF 22517-2 <sup>1</sup> / <sub>16</sub>	SAF 517	22217-CK	39700	HA 317	LER 53	1 SR-17-14	3	HE 317		
3 <sup>3</sup> / <sub>16</sub>	SAF 22518-3 <sup>3</sup> / <sub>16</sub>	SAF 518	22218-CK	47600	HA 318	LER 188	1 SR-18-15	3 <sup>1</sup> / <sub>4</sub>	HE 318	3 <sup>1</sup> / <sub>8</sub>	HS 318
3 <sup>7</sup> / <sub>16</sub>	SAF 22520-3 <sup>7</sup> / <sub>16</sub>	SAF 520	22220-CK	60600	HA 320	LER 102	1 SR-20-17	3 <sup>1</sup> / <sub>2</sub>	HE 320	3 <sup>3</sup> / <sub>8</sub>	HS 320
3 <sup>1</sup> / <sub>16</sub>	SAF 22522-3 <sup>1</sup> / <sub>16</sub>	SAF 522	22222-CK	79400	HA 322	LER 109	1 SR-22-19	4	HE 322	3 <sup>7</sup> / <sub>8</sub>	HS 322
4 <sup>3</sup> / <sub>16</sub>	SAF 22524-4 <sup>3</sup> / <sub>16</sub>	SAF 524	22224-CK	91500	HA 3124	LER 113	1 SR-24-20	4 <sup>1</sup> / <sub>4</sub>	HE 3124		
4 <sup>7</sup> / <sub>16</sub>	SAF 22526-4 <sup>7</sup> / <sub>16</sub>	SAF 526	22226-CK	108000	HA 3126	LER 117	1 SR-26-0	4 <sup>1</sup> / <sub>2</sub>	HE 3126		
4 <sup>1</sup> / <sub>16</sub>	SAF 22528-4 <sup>1</sup> / <sub>16</sub>	SAF 528	22228-CK	121300	HA 3128	LER 122	1 SR-28-0	5	HE 3128		
5 <sup>3</sup> / <sub>16</sub>	SAF 22530-5 <sup>3</sup> / <sub>16</sub>	SAF 530	22230-CK	144000	HA 3130	LER 125	1 SR-30-0	5 <sup>1</sup> / <sub>4</sub>	HE 3130		
5 <sup>7</sup> / <sub>16</sub>	SAF 22532-5 <sup>7</sup> / <sub>16</sub>	SAF 532	22232-CK	160600	HA 3132	LER 130	1 SR-32-0	5 <sup>1</sup> / <sub>2</sub>	HE 3132		
5 <sup>1</sup> / <sub>16</sub>	SAF 22534-5 <sup>1</sup> / <sub>16</sub>	SAF 534	22234-CK	182600	HA 3134	LER 140	1 SR-34-0	6	HE 3134		
6 <sup>7</sup> / <sub>16</sub>	SAF 22536-6 <sup>7</sup> / <sub>16</sub>	SAF 536	22236-CK	187000	HA 3136	LER 148	1 SR-36-30	6 <sup>1</sup> / <sub>2</sub>	HE 3136		
6 <sup>1</sup> / <sub>16</sub>	SAF 22538-6 <sup>1</sup> / <sub>16</sub>	SAF 538	22238-CK	206800	HA 3138	LER 155	1 SR-38-32	7	HE 3138		
7 <sup>3</sup> / <sub>16</sub>	SAF 22540-7 <sup>3</sup> / <sub>16</sub>	SAF 540	22240-CK	233200	HA 3140	LER 159	1 SR-40-34				
7 <sup>1</sup> / <sub>16</sub>	SAF 22544-7 <sup>1</sup> / <sub>16</sub>	SAF 544	22244-CK	286000	HA 3144	LER 167	1 SR-44-38				

- (\*) Size of triple seal will change with alternate shaft size.
- To obtain proper seal ring clearance for shaft diameter, refer to tolerance table, page 27.
- Please order "Fixing Ring" for fixed bearing. Use only one fixed bearing per shaft.
- Maintain this level for oil lubrication. Refer to page 24 and page 25 for further information on lubrication.

# ringball bearings Ltd.

**RBL SPLIT HOUSINGS**

SERIES

**SAF 500**

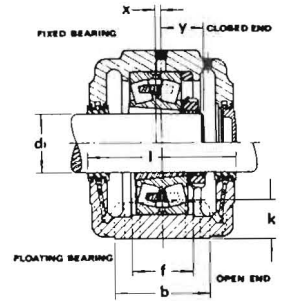
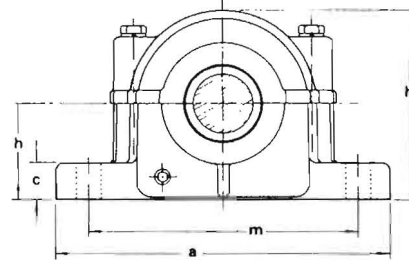

Housing number	h inch	a inch	b inch	c inch	m inch	h <sub>1</sub> inch	l inch	6) k inch	x inch	f inch	Bolt Size Req'd.		For Shaft sizes inch		
											2-bolt	4-bolt			
SAF 509	2 1/4	8 1/4	2 3/8	1 3/16	6 5/8	4 3/8	3 5/8	1	3/16		1/2	—	1 7/16	1 1/2	
SAF 510	2 1/2	8 1/4	2 3/8	1 5/16	6 3/4	4 3/4	3 5/8	1 1/8	3/16		1/2	—	1 11/16	1 3/4	1 5/8
SAF 511	2 3/4	9 5/8	2 3/4	1 5/16	7 5/8	5 1/4	3 7/8	1 1/4	3/16		5/8	—	1 15/16	2	1 7/8
SAF 513	3	11	3 1/8	1	8 13/16	5 15/16	4 1/2	1 1/8	3/16	2	5/8	1/2	2 3/16	2 1/4	2 3/8
SAF 515	3 1/4	11 1/4	3 1/8	1 1/8	9 1/8	6 3/8	4 3/4	1 1/4	3/16	1 7/8	5/8	1/2	2 7/16	2 1/2	
SAF 516	3 1/2	13	3 1/2	1 3/16	10 9/16	6 7/8	4 7/8	1 1/2	3/16	2 1/8	3/4	5/8	2 11/16	2 3/4	2 7/8
SAF 517	3 3/4	13	3 1/2	1 1/4	10 7/16	7 5/16	5	1 7/16	3/16	2 1/8	3/4	5/8	2 15/16	3	
SAF 518	4	13 3/4	3 7/8	1 5/16	11	7 3/4	5 3/4	1 1/2	3/16	2 1/8	3/4	5/8	3 3/16	3 1/4	3 1/8
SAF 520	4 1/2	15 1/4	4 3/8	1 3/4	12 3/8	8 3/4	6	1 3/4	3/16	2 3/8	7/8	3/4	3 7/16	3 1/2	3 5/8
SAF 522	4 15/16	16 1/2	4 3/4	2	13 9/16	9 5/8	6 1/2	1 7/8	3/16	2 3/4	—	3/4	3 15/16	4	3 7/8
SAF 524	5 1/4	16 1/2	4 3/4	2 1/8	13 7/8	10 1/4	7 3/8	1 15/16	3/16	2 3/4	—	3/4	4 3/16	4 1/4	
SAF 526	6	18 3/8	5 1/8	2 3/8	15 5/16	11 1/2	8	2 7/16	3/16	3 1/4	—	7/8	4 7/16	4 1/2	
SAF 528	6	20 1/8	5 7/8	2 3/8	16 9/16	11 3/4	7 5/8	2 1/8	3/16	3 3/8	—	1	4 15/16	5	
SAF 530	6 5/16	21 1/4	6 1/4	2 1/2	17 5/8	12 1/2	8 3/8	2 3/16	3/16	3 3/4	—	1	5 3/16	5 1/4	
SAF 532	6 11/16	22	6 1/4	2 5/8	18 5/16	13 5/16	8 3/4	2 3/16	3/16	3 3/4	—	1	5 7/16	5 1/2	
SAF 534	7 1/16	24 3/4	6 3/4	2 3/4	20 1/2	14 3/16	9 5/8	2 5/16	3/16	4 1/4	—	1	5 15/16	6	
SAF 536	7 1/2	26 3/4	7 1/8	3	22 1/2	14 7/8	10	2 9/16	3/16	4 5/8	—	1	6 7/16	6 1/2	
SAF 538	7 7/8	28	7 1/2	3 1/8	23	15 11/16	10 3/4	2 5/8	3/16	4 1/2	—	1 1/4	6 15/16	7	
SAF 540	8 1/4	29 1/2	8	3 3/8	23 3/4	16 1/2	11 1/4	2 11/16	3/16	5	—	1 1/4	7 3/16		
SAF 544	9 1/2	32 3/4	8 3/4	3 3/4	26 5/16	18 5/8	12	3 3/8	3/16	5 1/4	—	1 1/2	7 15/16		

3. (\*) Please specify 'FSAF' for 4-bolt base.

4. Permissible Radial Load for bearings may be found on page 22 and 23.

# ringball bearings Ltd.

## **RBL** SPLIT HOUSING PILLOW BLOCKS for spherical roller bearings with adapter sleeves

SERIES

**SAF 22600**

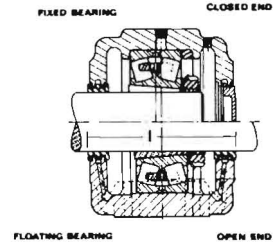
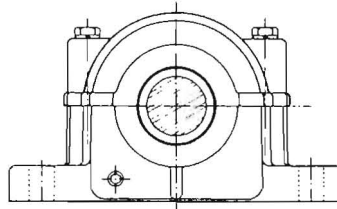

## CAST IRON - 2 or 4 BOLT ALSO AVAILABLE IN CAST STEEL — SPECIFY 'SAFS'

Standard Shaft dia. inch	Complete Pillow Block number	COMPONENT PART NUMBERS						Alternative Shaft Sizes *			
		Housing number	Bearing		Adapter Sleeve number	Triple Seal Rings (2 each)	Fixing Rings (No. req'd.)	dia. inch	Adapter number	dia. inch	Adapter number
			Bearing number	Dyn. Load Rtg. Lbs.							
1 <sup>1</sup> / <sub>16</sub>	SAF 22609-1 <sup>1</sup> / <sub>16</sub>	SAF 609	22309-CK	26500	HA 2309	LER 17	SR-11-9	1 <sup>1</sup> / <sub>2</sub>	HE 2309		
1 <sup>1</sup> / <sub>8</sub>	SAF 22610-1 <sup>1</sup> / <sub>8</sub>	SAF 610	22310-CK	33700	HA 2310	LER 20	SR-0-10	1 <sup>3</sup> / <sub>4</sub>	HE 2310	1 <sup>5</sup> / <sub>8</sub>	HS 2310
1 <sup>9</sup> / <sub>16</sub>	SAF 22611-1 <sup>9</sup> / <sub>16</sub>	SAF 611	22311-CK	38800	HA 2311	LER 24	SR-13-11	2	HE 2311	1 <sup>7</sup> / <sub>8</sub>	HS 2311
2 <sup>3</sup> / <sub>16</sub>	SAF 22613-2 <sup>3</sup> / <sub>16</sub>	SAF 613	22313-CK	48500	HA 2313	LER 32	SR-16-13	2 <sup>1</sup> / <sub>4</sub>	HE 2313	2 <sup>3</sup> / <sub>8</sub>	HS 2313
2 <sup>1</sup> / <sub>2</sub>	SAF 22615-2 <sup>1</sup> / <sub>2</sub>	SAF 615	22315-CK	66100	HA 2315	LER 37	SR-18-15	2 <sup>1</sup> / <sub>2</sub>	HE 2315	2 <sup>5</sup> / <sub>8</sub>	HS 2315
2 <sup>1</sup> / <sub>2</sub>	SAF 22616-2 <sup>1</sup> / <sub>2</sub>	SAF 616	22316-CK	71600	HA 2316	LER 44	SR-19-16	2 <sup>3</sup> / <sub>4</sub>	HE 2316	2 <sup>7</sup> / <sub>8</sub>	HS 2316
2 <sup>1</sup> / <sub>2</sub>	SAF 22617-2 <sup>1</sup> / <sub>2</sub>	SAF 617	22317-CK	73900	HA 2317	LER 184	SR-20-17	3	HE 2317		
3 <sup>3</sup> / <sub>16</sub>	SAF 22618-3 <sup>3</sup> / <sub>16</sub>	SAF 618	22318-CK	89300	HA 2318	LER 188	SR-21-18	3 <sup>1</sup> / <sub>4</sub>	HE 2318	3 <sup>1</sup> / <sub>8</sub>	HS 2318
3 <sup>7</sup> / <sub>16</sub>	SAF 22620-3 <sup>7</sup> / <sub>16</sub>	SAF 620	22320-CK	115000	HA 2320	LER 102	SR-24-20	3 <sup>1</sup> / <sub>2</sub>	HE 2320	3 <sup>5</sup> / <sub>8</sub>	HS 2320
3 <sup>1</sup> / <sub>2</sub>	SAF 22622-3 <sup>1</sup> / <sub>2</sub>	SAF 622	22322-CK	137000	HA 2322	LER 109	SR-0-22	4	HE 2322	3 <sup>7</sup> / <sub>8</sub>	HS 2322
4 <sup>3</sup> / <sub>16</sub>	SAF 22624-4 <sup>3</sup> / <sub>16</sub>	SAF 624	22324-CK	159000	HA 2324	LER 113	SR-0-24	4 <sup>1</sup> / <sub>4</sub>	HE 2324		
4 <sup>7</sup> / <sub>16</sub>	SAF 22626-4 <sup>7</sup> / <sub>16</sub>	SAF 626	22326-CK	183000	HA 2326	LER 117	SR-0-26	4 <sup>1</sup> / <sub>2</sub>	HE 2326		
4 <sup>1</sup> / <sub>2</sub>	SAF 22628-4 <sup>1</sup> / <sub>2</sub>	SAF 628	22328-CK	209000	HA 2328	LER 122	SR-0-28	5	HE 2328		
5 <sup>3</sup> / <sub>16</sub>	SAF 22630-5 <sup>3</sup> / <sub>16</sub>	SAF 630	22330-CK	233200	HA 2330	LER 125	SR-36-30	5 <sup>1</sup> / <sub>4</sub>	HE 2330		
5 <sup>7</sup> / <sub>16</sub>	SAF 22632-5 <sup>7</sup> / <sub>16</sub>	SAF 632	22332-CK	259600	HA 2332	LER 130	SR-38-32	5 <sup>1</sup> / <sub>2</sub>	HE 2332		
5 <sup>1</sup> / <sub>2</sub>	SAF 22634-5 <sup>1</sup> / <sub>2</sub>	SAF 634	22334-CK	288200	HA 2334	LER 140	SR-40-34	6	HE 2334		
6 <sup>7</sup> / <sub>16</sub>	SAF 22636-6 <sup>7</sup> / <sub>16</sub>	SAF 636	22336-CK	319000	HA 2336	LER 148	SR-0-36	6 <sup>1</sup> / <sub>2</sub>	HE 2336		
6 <sup>1</sup> / <sub>2</sub>	SAF 22638-6 <sup>1</sup> / <sub>2</sub>	SAF 638	22338-CK	347600	HA 2338	LER 155	SR-44-38	7	HE 2338		
7 <sup>3</sup> / <sub>16</sub>	SAF 22640-7 <sup>3</sup> / <sub>16</sub>	SAF 640	22340-CK	378400	HA 2340	LER 159	SR-0-40				

- (\*) Size of triple seal rings will change with alternative shaft size.
- To obtain proper seal ring clearance for shaft diameter, refer to tolerance table, page 27.
- Please order "Fixing Ring" for fixed bearing. Use only one fixed bearing per shaft.
- Maintain this level for oil lubrication. Refer to page 24 and 25 for further information on lubrication.

# ringball bearings Ltd.

**RBL SPLIT HOUSINGS**

SERIES

**SAF 600**

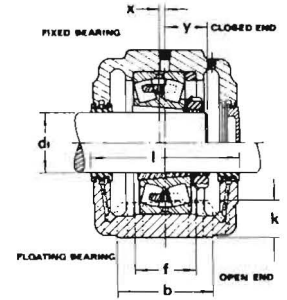
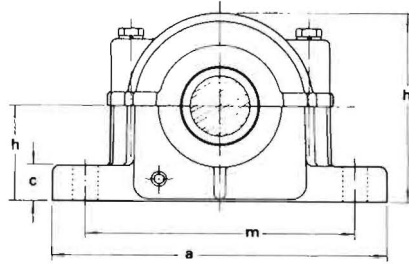

Housing number	h inch	a inch	b inch	c inch	m inch	h <sub>1</sub> inch	i inch	6) k inch	x inch	f inch	Bolt Size Req'd.		For Shaft sizes inch		
											2-bolt	4-bolt			
SAF 609	2 $\frac{3}{4}$	9 $\frac{5}{8}$	2 $\frac{3}{4}$	1	7 $\frac{5}{8}$	5 $\frac{5}{16}$	4 $\frac{1}{4}$	1 $\frac{5}{16}$	$\frac{3}{16}$		$\frac{5}{8}$	—	1 $\frac{7}{16}$	1 $\frac{1}{2}$	
SAF 610	3	10 $\frac{5}{8}$	2 $\frac{3}{4}$	1 $\frac{1}{8}$	8 $\frac{3}{8}$	5 $\frac{13}{16}$	4 $\frac{5}{8}$	1 $\frac{3}{8}$	$\frac{3}{16}$		$\frac{5}{8}$	—	1 $\frac{11}{16}$	1 $\frac{3}{4}$	1 $\frac{1}{8}$
SAF 611	3 $\frac{1}{4}$	11	3 $\frac{3}{8}$	1 $\frac{3}{16}$	8 $\frac{13}{16}$	6 $\frac{3}{16}$	4 $\frac{7}{8}$	1 $\frac{1}{2}$	$\frac{3}{16}$	2	$\frac{5}{8}$	$\frac{1}{2}$	1 $\frac{15}{16}$	2	1 $\frac{1}{8}$
SAF 613	3 $\frac{1}{2}$	13	3 $\frac{1}{2}$	1 $\frac{1}{4}$	10 $\frac{5}{16}$	6 $\frac{5}{16}$	5 $\frac{3}{8}$	1 $\frac{15}{32}$	$\frac{3}{16}$	2 $\frac{1}{8}$	$\frac{3}{4}$	$\frac{5}{8}$	2 $\frac{3}{16}$	2 $\frac{1}{4}$	2 $\frac{3}{8}$
SAF 615	4	13 $\frac{3}{4}$	3 $\frac{7}{8}$	1 $\frac{5}{16}$	11	7 $\frac{13}{16}$	6 $\frac{1}{4}$	1 $\frac{11}{16}$	$\frac{3}{16}$	2 $\frac{1}{8}$	$\frac{3}{4}$	$\frac{5}{8}$	2 $\frac{7}{16}$	2 $\frac{1}{2}$	2 $\frac{5}{8}$
SAF 616	4 $\frac{1}{4}$	14 $\frac{1}{4}$	3 $\frac{7}{8}$	1 $\frac{5}{16}$	11 $\frac{5}{8}$	8 $\frac{1}{4}$	6 $\frac{1}{2}$	1 $\frac{3}{4}$	$\frac{3}{16}$	2 $\frac{1}{8}$	$\frac{3}{4}$	$\frac{5}{8}$	2 $\frac{11}{16}$	2 $\frac{3}{4}$	2 $\frac{7}{8}$
SAF 617	4 $\frac{1}{2}$	15 $\frac{1}{4}$	4 $\frac{3}{8}$	1 $\frac{3}{4}$	12 $\frac{3}{8}$	8 $\frac{3}{4}$	6 $\frac{3}{4}$	1 $\frac{13}{16}$	$\frac{3}{16}$	2 $\frac{3}{8}$	$\frac{7}{8}$	$\frac{3}{4}$	2 $\frac{15}{16}$	3	
SAF 618	4 $\frac{3}{4}$	15 $\frac{1}{2}$	4 $\frac{3}{8}$	2	12 $\frac{3}{4}$	9 $\frac{3}{16}$	6 $\frac{7}{8}$	2	$\frac{3}{16}$	2 $\frac{1}{4}$	—	$\frac{3}{4}$	3 $\frac{3}{16}$	3 $\frac{1}{4}$	3 $\frac{1}{8}$
SAF 620	5 $\frac{1}{4}$	16 $\frac{1}{2}$	4 $\frac{3}{4}$	2 $\frac{1}{8}$	13 $\frac{3}{8}$	10 $\frac{1}{4}$	7 $\frac{3}{8}$	2 $\frac{1}{8}$	$\frac{3}{16}$	2 $\frac{3}{4}$	—	$\frac{3}{4}$	3 $\frac{7}{16}$	3 $\frac{1}{2}$	3 $\frac{5}{8}$
SAF 622	6	18 $\frac{3}{8}$	5 $\frac{1}{8}$	2 $\frac{3}{8}$	15 $\frac{5}{16}$	11 $\frac{1}{2}$	8	2 $\frac{1}{2}$	$\frac{3}{16}$	3 $\frac{1}{4}$	—	$\frac{7}{8}$	3 $\frac{15}{16}$	4	3 $\frac{7}{8}$
SAF 624	6 $\frac{5}{16}$	21 $\frac{1}{4}$	6 $\frac{1}{4}$	2 $\frac{1}{2}$	17 $\frac{5}{8}$	12 $\frac{1}{2}$	8 $\frac{3}{8}$	2 $\frac{9}{16}$	$\frac{3}{16}$	3 $\frac{3}{4}$	—	1	4 $\frac{3}{16}$	4 $\frac{1}{4}$	
SAF 626	6 $\frac{11}{16}$	22	6 $\frac{1}{4}$	2 $\frac{5}{8}$	18 $\frac{5}{16}$	13 $\frac{5}{16}$	8 $\frac{3}{4}$	2 $\frac{5}{8}$	$\frac{3}{16}$	3 $\frac{3}{4}$	—	1	4 $\frac{7}{16}$	4 $\frac{1}{2}$	
SAF 628	7 $\frac{1}{16}$	24 $\frac{3}{4}$	6 $\frac{3}{4}$	2 $\frac{3}{4}$	20 $\frac{1}{2}$	14 $\frac{3}{16}$	9 $\frac{3}{8}$	2 $\frac{11}{16}$	$\frac{3}{16}$	4 $\frac{1}{4}$	—	1	4 $\frac{15}{16}$	5	
SAF 630	7 $\frac{1}{2}$	26 $\frac{3}{4}$	7 $\frac{7}{8}$	3	22 $\frac{1}{4}$	14 $\frac{7}{8}$	9 $\frac{3}{4}$	2 $\frac{7}{8}$	$\frac{3}{16}$	4 $\frac{5}{8}$	—	1	5 $\frac{3}{16}$	5 $\frac{1}{4}$	
SAF 632	7 $\frac{7}{8}$	28	7 $\frac{1}{2}$	3 $\frac{3}{8}$	23	15 $\frac{11}{16}$	10 $\frac{5}{8}$	2 $\frac{15}{16}$	$\frac{3}{16}$	4 $\frac{1}{2}$	—	1 $\frac{1}{4}$	5 $\frac{7}{16}$	5 $\frac{1}{2}$	
SAF 634	8 $\frac{1}{4}$	29 $\frac{1}{2}$	8	3 $\frac{3}{8}$	23 $\frac{3}{4}$	16 $\frac{1}{2}$	11 $\frac{1}{4}$	3 $\frac{1}{16}$	$\frac{3}{16}$	5	—	1 $\frac{1}{4}$	5 $\frac{15}{16}$	6	
SAF 636	8 $\frac{7}{8}$	31 $\frac{1}{4}$	8 $\frac{1}{4}$	3 $\frac{1}{2}$	25 $\frac{5}{16}$	17 $\frac{3}{4}$	11 $\frac{3}{8}$	3 $\frac{3}{8}$	$\frac{3}{16}$	5 $\frac{1}{4}$	—	1 $\frac{1}{4}$	6 $\frac{7}{16}$	6 $\frac{1}{2}$	
SAF 638	9 $\frac{1}{2}$	32 $\frac{3}{4}$	8 $\frac{3}{4}$	3 $\frac{3}{4}$	26 $\frac{3}{8}$	18 $\frac{5}{8}$	11 $\frac{7}{8}$	3 $\frac{1}{16}$	$\frac{3}{16}$	5 $\frac{1}{4}$	—	1 $\frac{1}{2}$	6 $\frac{15}{16}$	7	
SAF 640	9 $\frac{7}{8}$	34 $\frac{1}{4}$	9	4	27 $\frac{7}{8}$	20	12 $\frac{1}{16}$	3 $\frac{3}{4}$	$\frac{3}{16}$	5 $\frac{1}{2}$	—	1 $\frac{1}{2}$	7 $\frac{3}{16}$		

3. (\*) Please specify 'FSAF' for 4-bolt base.

4. Permissible Radial Load for bearings may be found on page 22 and 23.

# ringball bearings ltd.

## ASSEMBLY INSTRUCTIONS Adapter Mounting

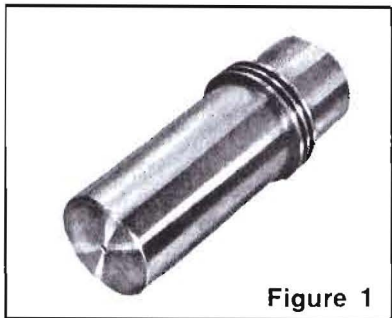

### 1. INNER TRIPLE SEAL

Slide the inner triple seal on the shaft. It will freely slide into position. (Figure 1).



### 2. ADAPTER SLEEVE

Slide adapter sleeve on the shaft with threads to outside. Locate sleeve where bearing centerline will be. For easier bearing mounting or removal, apply micronized or unflaked powdered graphite to outside diameter surface of sleeve. (Figure 2).

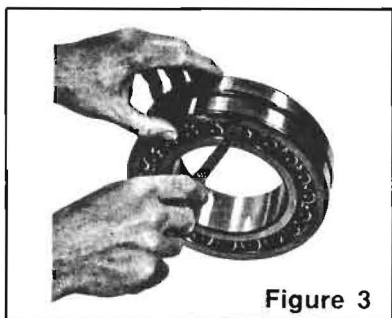

### 3. UNMOUNTED CLEARANCE

A simple step for measuring unmounted internal bearing clearance is to insert progressively larger thickness feeler blades the full length of roller between the most vertical unloaded roller and outer bearing ring. Slide feeler blade through the clearance; do not attempt to roll it through. The largest size blade that slides through indicates the unmounted internal clearance. (Figure 3).

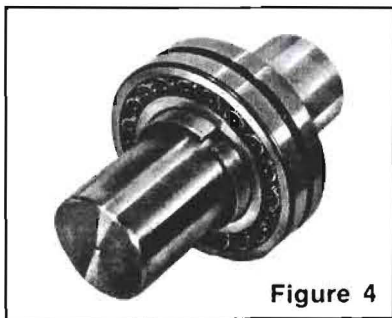

### 4. BEARING

Mount bearing on adapter sleeve, starting with large bore of inner ring to match taper of adapter. With bearing hand-tight on the adapter, locate bearing to proper axial position on shaft. Leave lockwasher off until you have finished the next step. (Figure 4).

### 5. LOCKNUT

With chamfered face toward the bearing, apply locknut. A coating of graphite on face of locknut where it contacts bearing will make mounting easier. Keep in mind that a heavy duty spanner wrench and extension are needed to obtain required reduction in internal clearance on large size bearings. Do not tighten locknut with hammer and drift, as this may damage locknut and chips can enter the bearing. Tighten locknut and measure internal clearance with feeler blades between most vertical unloaded roller and outer ring until clearance is less than the figure measured in (3). Refer to table on Page 26 to determine proper amount of reduction in internal clearance.

In the case of self-aligning ball bearings, the adapter sleeve may only be tightened to the extent that the outer ring can still be rotated and tilted without offering resistance. (Figure 5).

# ringball bearings ltd.

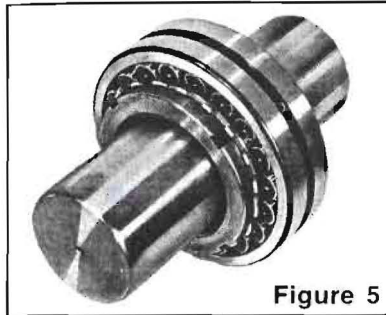

## 6. LOCKNUT AND LOCKWASHER

Remove locknut and mount lockwasher on adapter sleeve with inner prong of lockwasher toward face of bearing and in slot of adapter sleeve. Re-apply locknut until tight. Care should be taken not to force the bearing further up the taper since this will reduce the internal clearance previously determined. Check to be certain clearance has not changed. Find lockwasher tang nearest a locknut slot. If slot is slightly past tang, do not loosen nut; tighten to meet a washer tang. (Figure 6).

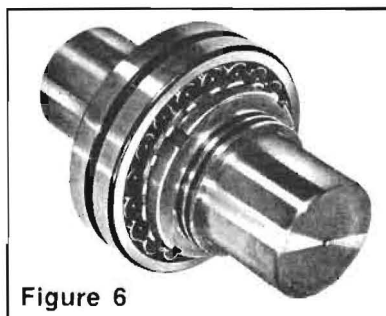

## 7. OUTER TRIPLE SEAL

Slide outer triple seal on the shaft. Locate both inner triple seal and outer triple seal to match labyrinths in housing. (Figure 7).

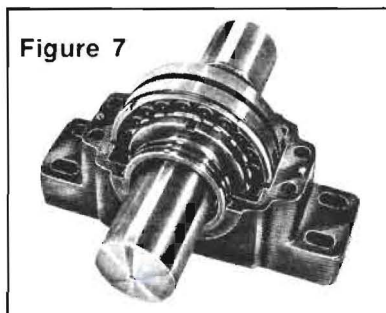

## 8. LOWER HALF OF HOUSING

Thoroughly clean housing and remove any paint or burrs from the mating surfaces at the split. The vertical hole in the lower part of each enclosure groove must be free from foreign matter. When using triple seal rings, guide seals carefully into enclosure grooves. Bolt fixed housing in place. (Figures 8 and 9).

8a. For felt seal housings, soak the felt strips in oil, pack into the grooves, and cut off level with the mating surface at the split to ensure correct fitting of the housing halves. Place shaft with bearings into lower half of housing and ensure that bearing outer ring is correctly seated. (Figures 8 and 9).

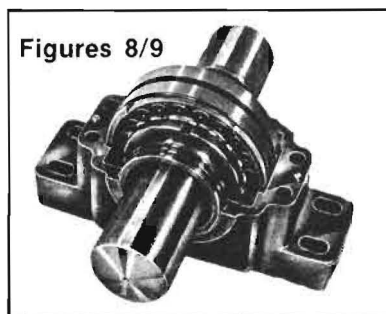

## 9. FIXING RING

Move shaft axially so that fixing ring may be inserted between "fixed" bearing outer ring and housing shoulder on locknut side of bearing. Center all other bearings on one shaft in their housing seats. It is important that there is only one "fixed" bearing per shaft. All other bearings must be floating to permit shaft expansion. If the split housing is to have a closed end, an end cover is fitted snugly into triple seal groove in place of the triple seal. It is inserted in lower half of housing before upper half is bolted to base. If grease is used as a lubricant, it should be applied to the bearing. Lubrication on Page 24. (Figures 8/9).

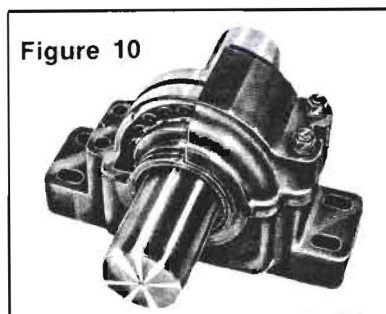

## 10. UPPER HALF OF HOUSING

The bearing seat in the upper half of the housing or cap should be deburred, thoroughly cleaned, oiled and placed over bearing. A sealing compound may be used between the mating surfaces of the cap and base to eliminate lubricant leakages. The two dowel pins will align upper half of housing. It is important to note that caps and bases of split housings are not interchangeable. Each cap and base must be assembled with its mating part. Lockwashers and capbolts are next applied and tightened to complete the assembly. (Figure 10).

10a. For felt seal housings, pack the remaining strips into the grooves of housing. (Figure 10).

# ringball bearings ltd.

## RADIAL LOAD RATING TABLES (in pounds)

FOR 'RBL' PILLOW BLOCKS BEARING SERIES 1200 or 1200-K									FOR 'RBL' PILLOW BLOCKS BEARING SERIES 1300 or 1300-K								
Bearing Number	Life Hours	rpm							Bearing Number	Life Hours	rpm						
		100	500	750	1200	1500	1800	3600			100	500	750	1200	1500	1800	3600
1205	5000	675	395	345	295	275	260	205	1305	5000	1000	585	510	440	410	380	300
	15000	470	275	240	205	190	180	140		15000	695	405	355	300	280	265	210
	30000	370	220	190	160	150	140	110		30000	550	320	280	240	225	210	170
1206	5000	870	510	445	380	355	330	265	1306	5000	1190	695	610	520	485	455	360
	15000	605	355	310	265	245	230	180		15000	825	480	420	360	335	315	250
	30000	480	280	245	210	195	180	145		30000	655	380	335	285	265	250	200
1207	5000	880	515	450	385	360	335	270	1307	5000	1400	820	715	610	570	535	425
	15000	610	360	310	270	250	230	185		15000	970	570	500	425	395	370	295
	30000	485	285	250	210	200	185	150		30000	770	450	395	340	310	295	230
1208	5000	1070	630	550	470	435	410	325	1308	5000	1650	960	840	720	670	630	500
	15000	740	435	380	325	300	285	225		15000	1140	670	585	500	460	435	345
	30000	590	345	300	260	240	225	180		30000	905	530	460	395	370	345	275
1209	5000	1220	710	620	530	495	465	370	1309	5000	2120	1240	1090	930	860	810	640
	15000	845	490	430	370	340	320	255		15000	1470	860	755	640	600	560	445
	30000	670	390	340	290	270	255	200		30000	1170	685	600	510	475	445	355
1210	5000	1270	740	650	550	515	480	380	1310	5000	2420	1410	1240	1060	980	920	730
	15000	880	510	450	380	355	335	265		15000	1680	980	860	730	680	640	510
	30000	695	410	355	305	280	265	210		30000	1330	780	680	580	540	510	400
1211	5000	1490	870	760	650	605	570	450	1311	5000	2830	1660	1450	1240	1150	1080	860
	15000	1030	605	530	450	420	394	310		15000	1960	1150	1010	860	800	750	595
	30000	820	480	420	360	330	310	250		30000	1560	910	800	680	635	595	470
1212	5000	1670	980	860	730	680	640	510	1312	5000	3170	1860	1620	1390	1290	1210	960
	15000	1160	680	595	510	470	440	350		15000	2200	1290	1130	960	895	840	665
	30000	920	540	470	400	375	350	280		30000	1750	1020	895	760	710	665	530
1213	5000	1730	1010	880	750	700	660	520	1313	5000	3440	2010	1760	1500	1400	1310	1040
	15000	1200	700	610	520	485	455	360		15000	2390	1400	1220	1040	970	910	720
	30000	950	555	485	415	385	360	290		30000	1990	1110	970	830	770	720	575
1215	5000	2160	1260	1110	940	875	825	655	1314	5000	4150	2430	2130	1810	1690	1580	1260
	15000	1500	875	765	655	610	570	450		15000	2880	1680	1475	1260	1170	1100	870
	30000	1190	695	610	520	480	450	360		30000	2290	1340	1170	1000	930	870	690
1216	5000	2200	1280	1120	960	890	840	665	1315	5000	4410	2580	2260	1930	1790	1680	1340
	15000	1520	890	780	665	620	580	460		15000	3060	1790	1570	1340	1240	1170	925
	30000	1210	705	620	530	490	460	365		30000	2430	1420	1240	1060	985	925	735
1217	5000	2740	1600	1400	1200	1110	1040	830	1316	5000	4920	2880	2520	2150	2000	1880	1490
	15000	1900	1110	970	830	770	725	575		15000	3410	2000	1750	1490	1390	1300	1030
	30000	1510	880	770	660	610	575	455		30000	2710	1590	1390	1180	1100	1030	820
1218	5000	3110	1820	1590	1360	1260	1190	940	1317	5000	5440	3180	2780	2380	2210	2080	1650
	15000	2160	1260	1100	940	875	825	655		15000	3770	2210	1930	1650	1530	1440	1140
	30000	1710	1000	875	695	695	655	520		30000	2990	1750	1530	1310	1220	1140	910
1219	5000	3545	2075	1810	1550	1435	1355	1075	1318	5000	6500	3800	3330	2840	2640	2480	
	15000	2455	1435	1255	1075	995	940	745		15000	4510	2640	2310	1970	1830	1720	
	30000	1950	1140	995	850	790	745	590		30000	3580	2090	1830	1560	1450	1370	
1220	5000	3800	2225	1940	1660	1540	1450	1150	1320	5000	7980	4670	4090	3490	3240	3050	
	15000	2635	1540	1345	1150	1070	1005	800		15000	5530	3240	2830	2420	2250	2110	
	30000	2090	1225	1070	915	850	800	635		30000	4390	2570	2250	1920	1790	1680	
1222	5000	4830	2830	2470	2110	1960	1845	1465	1321	5000	8660	5060	4430	3780	3520	3300	
	15000	3350	1960	1715	1465	1360	1280	1015		15000	6000	3510	3070	2620	2440	2290	
	30000	2660	1555	1360	1160	1080	1015	805		30000	4760	2790	2440	2080	1940	1820	
1322	5000	9080	5310	4650	3960	3690	3460		1322	5000	9080	5310	4650	3960	3690	3460	
	15000	6290	3680	3220	2750	2560	2400			15000	6290	3680	3220	2750	2560	2400	
	30000	5000	2920	2560	2180	2030	1910			30000	5000	2920	2560	2180	2030	1910	

NOTE: For speeds to the left of the tinted area, grease lubrication is permissible. For speeds to the right of the tinted area, oil bath lubrication is recommended. In special cases, consult Ringball

# ringball bearings ltd.

FOR 'RBL' PILLOW BLOCKS BEARING SERIES 22200 or 22200-K									FOR 'RBL' PILLOW BLOCKS BEARING SERIES 22300 or 22300-K								
Bearing Number	Life Hours	rpm							Bearing Number	Life Hours	rpm						
		100	500	750	1200	1500	1800	3600			100	500	750	1200	1500	1800	3600
22208C	5000 15000 30000	5150 3710 3010	3180 2290 1860	2820 2030 1650	2570 1760 1430	2290 1650 1340	2170 1560 1270	1760 1270 1030	22308C	5000 15000 30000	7930 5700 4630	4890 3520 2860	4330 3120 2700	3760 2700 2200	3580 2530 2060	3330 2400 1950	2700 1950 1580
22209C	5000 15000 30000	5410 3890 3160	3340 2400 1950	2950 2130 1730	2570 1850 1500	2400 1730 1400	2270 1630 1330	1850 1330 1080	22309C	5000 15000 30000	9730 7000 5690	6000 4320 3510	5320 3820 3110	4620 3320 2700	4320 3110 2520	4090 2940 2390	3320 2390 1940
22210C	5000 15000 30000	5620 4040 3290	3470 2500 2030	3070 2210 1800	2670 1920 1560	2500 1800 1460	2360 1700 1380	1920 1380 1120	22310C	5000 15000 30000	12300 8820 7160	7560 5440 4420	6700 4820 3910	5820 4180 3400	5440 3910 3180	5120 3700 3000	4180 3000 2440
22211C	5000 15000 30000	6960 5000 4060	4290 3090 2510	3800 2730 2220	3300 2370 1930	3090 2220 1800	2920 2100 1710	2370 1710 1390	22311C	5000 15000 30000	13700 9850 8000	8450 6100 4940	7480 5380 4370	6500 4670 3800	6080 4370 3500	5760 4140 3360	
22212C	5000 15000 30000	8510 6120 4970	5250 3780 3070	4650 3340 2720	4040 2900 2360	3780 2720 2200	3570 2570 2090	2900 2090 1700	22312C	5000 15000 30000	16400 11800 9580	10100 7300 5910	8960 6450 5240	7780 5600 4550	7280 5240 4250	6900 4960 4030	
22213C	5000 15000 30000	10100 7260 5900	6230 4480 3640	5510 3970 3220	4790 3440 2800	4490 3220 2620	4240 3050 2480		22313C	5000 15000 30000	17700 12700 10300	10900 7840 6370	9650 6940 5640	8380 6030 4900	7840 5640 4580	7420 5340 4340	
22214C	5000 15000 30000	10500 7520 6110	6450 4640 3770	5710 4110 3340	4960 3570 2900	4640 3340 2710	4390 3160 2570		22314C	5000 15000 30000	20500 14800 12000	12700 9120 7400	11200 8070 6560	9750 7010 5700	9120 6560 5330	8630 6210 5050	
22215C	5000 15000 30000	11000 7910 6420	6780 4880 3960	6010 4230 3510	5220 3750 3050	4880 3510 2860	4620 3320 2700		22315C	5000 15000 30000	24500 17600 14300	15100 10900 8840	13400 9630 7820	11600 8360 6800	10900 7820 6360	10300 7400 6020	
22216C	5000 15000 30000	12300 8820 7160	7560 5440 4420	6700 4820 3910	5820 4180 3400	5440 3910 3100	5150 3700 3010		22316C	5000 15000 30000	26500 19100 15500	16300 11800 9550	14500 10400 8460	12600 9040 7350	11600 8460 6870	11100 8000 6500	
22217C	5000 15000 30000	14100 10100 8210	8670 6240 5070	7680 5520 4490	6670 4800 3900	6240 4490 3650	5910 4250 3450		22317C	5000 15000 30000	30000 21500 17500	18500 13300 10800	16300 11800 9550	14200 10200 8300	13300 9550 7760	12600 9040 7340	
22218C	5000 15000 30000	17100 12300 10000	10600 7600 6170	9360 6730 5470	8120 5840 4750	7600 5470 4440	7200 5170 4200		22318C	5000 15000 30000	33500 24100 19600	20700 14900 12100	18300 13200 10700	15900 11400 9300	14900 10700 8690	14100 10100 8230	
22220C	5000 15000 30000	22000 15800 12800	13600 9760 7900	12000 8640 7020	10400 7500 6100	9760 7020 5700	9240 6600 5400		22320C	5000 15000 30000	42500 30600 24800	26200 18900 15300	23200 16700 13600	20200 14500 11800	18900 13600 11000	17900 12900 10400	
22222C	5000 15000 30000	28800 20700 16800	17800 12800 10400	15800 11300 9200	13700 9840 8000	12800 9200 7480	12100 8700 7100		22322C	5000 15000 30000	50500 36300 29500	31100 22400 18200	27600 19800 16100	24000 17200 14000	22400 16100 13100		
22224C	5000 15000 30000	33000 23700 19300	20400 14600 11900	18000 13000 10600	15700 11300 9140	14600 10600 8550	13900 9970 8100		22324C	5000 15000 30000	59800 43000 35000	36900 26600 21600	32700 23500 19100	28400 20400 16600	26600 19100 15500		
22226C	5000 15000 30000	38900 28000 22700	24000 17300 14000	21300 15300 12400	18500 13300 10800	17300 12400 10100			22326C	5000 15000 30000	68500 49300 40000	42300 30400 24700	37400 26900 21900	32500 23400 19000			
22228C	5000 15000 30000	43300 31100 25300	26700 19200 15600	23600 17000 13800	20500 14800 12000				22328C	5000 15000 30000	79300 57000 46300	48900 35200 28600	43300 31200 25300	37600 27100 22000			
22230C	5000 15000 30000	51500 37100 30100	31800 22900 18600	28200 20300 16500	24500 17600 14300				22330C	5000 15000 30000	90100 64800 52600	55600 40000 32500	49200 35400 28800	42800 30800 25000			
22232C	5000 15000 30000	61300 44100 35800	37800 27200 22100	33500 24100 19600	29100 20900 17000				22332C	5000 15000 30000	97300 70000 57000	60000 43200 35100	53200 38200 31100				
22234C	5000 15000 30000	68500 49300 40400	42300 30400 24700	37400 26900 21900					22334C	5000 15000 30000	110000 79100 64200	67800 48800 39600	60100 43200 35100				
22236C	5000 15000 30000	70700 50800 41300	43600 31400 25500	38600 27800 22600					22336C	5000 15000 30000	121800 86900 70500	74500 53600 43500	66000 47500 38500				
22238C	5000 15000 30000	77900 56000 45500	48000 34600 28100	42500 30600 24900					22338C	5000 15000 30000	130000 93300 75800	80100 57600 46800	70900 51000 41400				
22240C	5000 15000 30000	88300 63500 51600	54500 39200 31800	48300 34700 28200					22340C	5000 15000 30000	140600 101100 82100	86700 62400 50700	76800 55200 44900				
22244C	5000 15000 30000	108100 77800 63200	66700 48000 39000	59100 42500 34500													

# ringball bearings Ltd.

## LUBRICATION

The selection of the proper type of lubricant and lubrication system for spherical roller & self-aligning ball bearing pillow blocks is based on a combination of several factors depending on operating temperature, speed and design conveniences.

### GREASE LUBRICATION

Since the simplest design that will accomplish the job is usually the best design, thought should first be given to the possibility of grease lubrication. Here the factors to be considered are:

1. Operating temperature should be below 200° F.
2. Load and speed should be within the limits shown in the "Load-Capacity" tables.
3. Correct type and grade of grease should be used.
4. Correct quantity of grease should be applied.

Excess grease in a pillow block may result in high induced temperatures; therefore the quantity of grease should be kept at approximately 1/3 to 1/2 of the free air space. A regreasing schedule based on operating conditions should be drawn up and adhered to. For general purpose applications, a grade #2 sodium or lithium soap grease will provide good service. Because of the variety of oils, bases and additives used in present day greases, it is not good practice to mix greases of different types and makes. Where contamination or other operating conditions are severe, the **Ringball Engineering Department** should be consulted.

### OIL LUBRICATION

Although oil lubrication will allow roller bearings to run at speeds and temperatures higher than those permissible with grease, it is essential that the following points be observed:

1. Only high quality petroleum oil should be used.
2. The oil should have a minimum viscosity of 100 SUS at the operating temperature.
3. The correct quantity must be applied.

Petroleum oils of poor quality, animal oils and vegetable oils tend to oxidize easily and form sludge deposits on the bearing parts. In order to provide an oil film of the correct shear strength, an oil with a minimum viscosity of 100 SUS at the operating temperature should be used. As the viscosity falls below this level, the bearing life will be reduced. For example, a bearing running in a fluid with a viscosity of 25 SUS may be expected to have a life equal to 1% of calculated life.

The quantity of oil used in ball and roller bearings is quite critical. Too much oil will result in churning and excess heat. Too little oil will not coat the load surfaces adequately and will result in early failures. Where a splash system is used, the oil level should be maintained at the mid-point of the lowest roller when the bearing is stationary. Drop feed systems and mist systems should be adjusted on a flow versus operating temperature basis.

# ringball bearings Ltd.

## LUBRICATION

The Oil Selection chart on this page may be used as a guide in selecting the proper oil viscosity. Find the operating temperature on the bottom scale, then go up vertically to or past the blue line until it intersects one of the slanted lines. For example, at 170° F we would have to go past the heavy blue line to find the first intersecting slanted line to be number "4". Number "4" is SAE 40 oil.

The limiting speed for grease and splash oil are shown in the "Radial Load Rating" tables. If a circulating oil system is used, a limiting speed of 150% of the grease limits is used. These limiting speeds are conservative and can be increased with experience on the specific application.

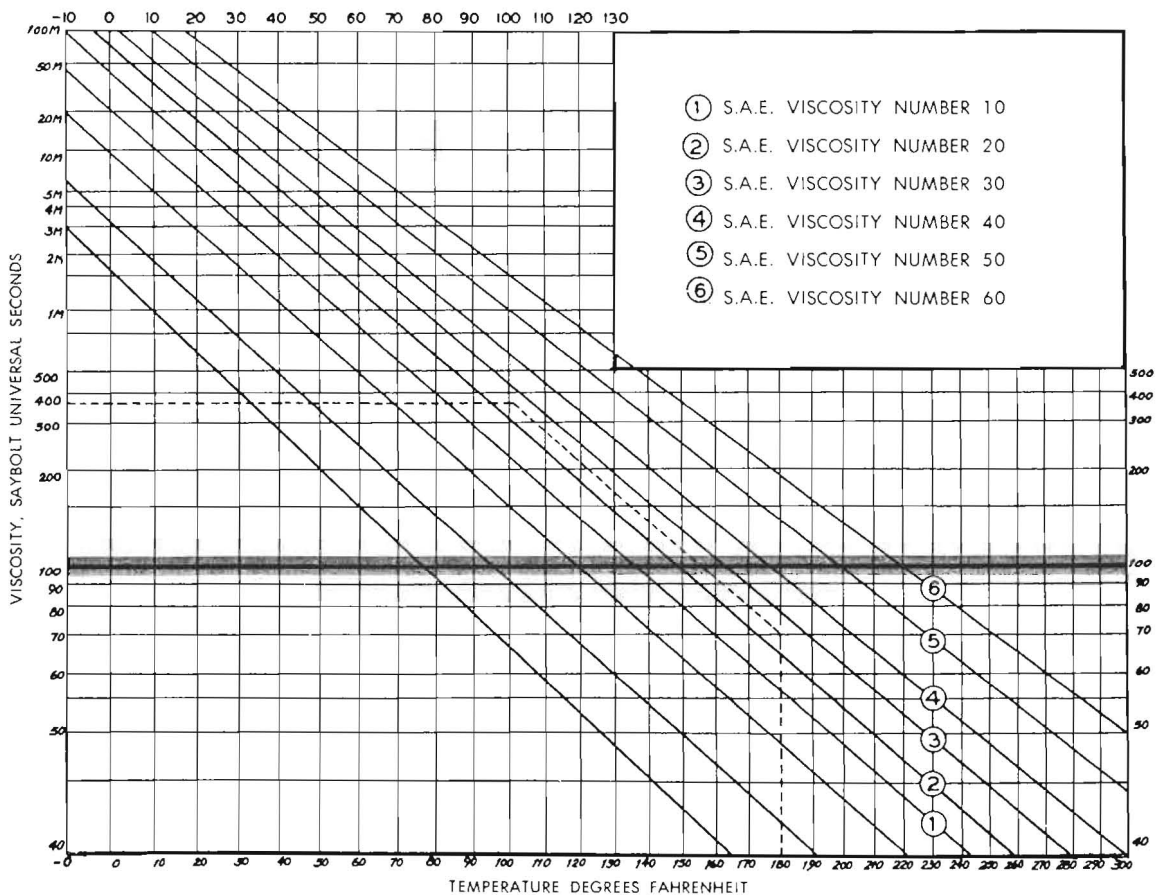

# ringball bearings Ltd.

## Mounting of Tapered Bore Spherical Roller Bearings

Bearings with tapered bore are mounted either on tapered shaft seats or with adapter or withdrawal sleeves on cylindrical shafts.

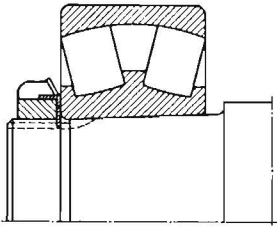

Mounting of a spherical roller bearing with tapered bore onto a tapered shaft seat with the help of a locknut

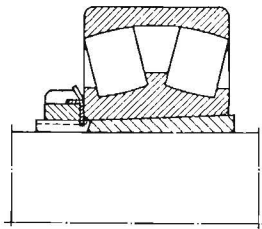

Mounting of a spherical roller bearing with tapered bore with an adapter sleeve assembly

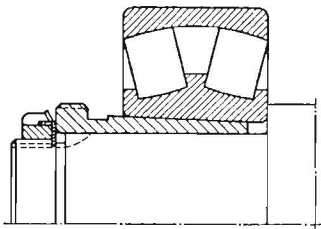

Mounting of a spherical roller bearing with tapered bore with a withdrawal sleeve assembly

The mounting of bearings with tapered bore not only results in a reduction of their radial internal clearance, but also in a measurable axial movement on a tapered shaft seat or sleeve. The actual measure of axial movement or reduction in radial clearance is indicative of the measure of fit interference. The respective values for spherical roller bearings can be found in the following table. The radial internal clearance of these bearings can be measured with feeler gauges.

Permissible reduction of radial clearance in spherical roller bearings with tapered bore when mounted on tapered shaft seats or adapter or withdrawal sleeves.

Bearing Bore		Radial Clearance before mounting		Reduction of radial clearance		Minimum Radial Clearance after mounting	Axial displacement of sleeve taper 1:12
in	mm	inch		inch		inch	inch
over	to	minimum	maximum	minimum	maximum		
<b>NORMAL RADIAL CLEARANCE</b>							
30	40	.0014	.0020	.0008	.0010	.0006	.014 to .016
40	50	.0018	.0024	.0010	.0012	.0008	.016 to .018
50	65	.0022	.0030	.0012	.0016	.0010	.018 to .024
65	80	.0026	.0036	.0016	.0020	.0010	.024 to .030
80	100	.0032	.0044	.0018	.0024	.0014	.028 to .036
100	120	.0040	.0054	.0020	.0028	.0020	.030 to .044
120	140	.0048	.0064	.0026	.0036	.0022	.044 to .056
140	160	.0052	.0072	.0030	.0040	.0022	.045 to .065
160	180	.0056	.080	.0032	.0044	.0024	.052 to .068
180	200	.0064	.0088	.0036	.0048	.0028	.056 to .076
200	225	.0072	.0100	.0040	.0056	.0032	.064 to .088
<b>RADIAL CLEARANCE C3</b>							
30	40	.0020	.0026	.0010	.0012	.0010	.016 to .018
40	50	.0024	.0032	.0012	.0016	.0012	.018 to .024
50	65	.0030	.0038	.0016	.0020	.0014	.024 to .030
65	80	.0036	.0048	.0020	.0024	.0016	.030 to .036
80	100	.0044	.0056	.0024	.0028	.0020	.036 to .044
100	120	.0054	.0068	.0028	.0036	.0026	.044 to .056
120	140	.0064	.0080	.0032	.0040	.0032	.052 to .064
140	160	.0072	.0092	.0036	.0048	.0036	.056 to .072
160	180	.0080	.0104	.0040	.0056	.0040	.064 to .088
180	200	.0088	.0116	.0048	.0064	.0040	.076 to .100
200	225	.0100	.0128	.0052	.0072	.0048	.080 to .112

It is not possible to measure the reduction in radial clearance of double row self-aligning or deep groove ball bearings. To properly assess the measure of fit interference when these bearing types with tapered bore are mounted, either their axial displacement is measured or their radial looseness is consistently checked by rotating the bearing by hand during the mounting procedure. Too much fit interference would, of course, lead to an excessive reduction in radial clearance. It may be safely assumed that the reduction of radial clearance is one fifteenth of the axial displacement between a tapered bore bearing and its tapered shaft seat or sleeve.

# ringball bearings Ltd.

## CLEANING

You may have to clean bearings when they have been removed from their positions, during overhaul of equipment or to remove accumulated dirt or deteriorated lubricants.

To clean unmounted bearings, use a clean petroleum solvent or kerosene. You may soak the bearings in a hot light oil (200° F maximum) or if you have extremely oxidized greases, you may boil in an emulsifying cleaner. If compressed air is used, be sure it is clean ... do not allow the bearing to spin during blowing. After all solvents have been removed, coat bearing with petroleum and reinstall in the pillow block or wrap in clean oil-proof paper while awaiting reassembly.

To clean mounted bearings, flush a hot, light oil (180° to 200° F) through the housing while rotating the shaft slowly. A hot aqueous emulsion may be used as a flush. When the bearing is clean, remove all solvents and flush housing and bearing with a hot, light oil. Relubricate with the recommended lubricant.

## SHAFT TOLERANCE LIMITS FOR ADAPTER MOUNTING

Nominal Shaft Diameter inch		Diameter Tolerance		Maximum permissible taper and ovality
OVER	INCL.	INCH		INCH
1/2	1	+ .000	— .002	.0004
1	2	+ .000	— .003	.0005
2	4	+ .000	— .004	.0006
4	8	+ .000	— .005	.0008

## Housing Material Specifications

MATERIAL	SPECIFICATION	TENSILE STRENGTH	YIELD STRENGTH	ELONGATION
CAST IRON	ASTM A48 GRADE 35	35000 PSI	—	—
DUCTILE IRON	ASTM A536 GRADE 65-45-12	65000 PSI	45000 PSI	12%
CAST STEEL	ASTM A27 GRADE 65-35	65000 PSI	35000 PSI	24%

# ringball bearings ltd.

## New Fixing Ring Dimensions for 'RBL' SN—S Housings

Catalogued Dimensions	New Dimensions
2 pcs. 62/ 8.5 mm	1 pc. 62/ 7 mm 1 pc. 62/10 mm
2 pcs. 72/ 9 mm	1 pc. 72/ 8 mm 1 pc. 72/10 mm
2 pcs. 80/ 7.5 mm	1 pc. 80/ 7 mm 1 pc. 80/ 8 mm
2 pcs. 90/ 6.5 mm	1 pc. 90/ 6 mm 1 pc. 90/ 7 mm
2 pcs. 100/10.5 mm	1 pc. 100/10 mm 1 pc. 100/11 mm
2 pcs. 110/11.5 mm	1 pc. 110/11 mm 1 pc. 110/12 mm
2 pcs. 140/ 8.5 mm	1 pc. 140/ 7 mm 1 pc. 140/10 mm
2 pcs. 150/ 9 mm	1 pc. 150/ 8 mm 1 pc. 150/10 mm
2 pcs. 160/11.2 mm	1 pc. 160/10 mm 1 pc. 160/12.4 mm
2 pcs. 160/16.2 mm	1 pc. 160/12.4 mm 2 pc. 160/10 mm
2 pcs. 170/14.5 mm	1 pc. 170/12 mm 1 pc. 170/17 mm
2 pcs. 180/14.5 mm	1 pc. 180/12 mm 1 pc. 180/17 mm
2 pcs. 190/15.5 mm	1 pc. 190/15 mm 1 pc. 190/16 mm
2 pcs. 200/13.5 mm	1 pc. 200/12 mm 1 pc. 200/15 mm
2 pcs. 215/18 mm	1 pc. 215/16 mm 2 pc. 215/10 mm
2 pcs. 240/20 mm	4 pcs. 240/10 mm
2 pcs. 270/16.5 mm	1 pc. 270/16 mm 1 pc. 270/17 mm



## ringball bearings ltd.

**MONTREAL**  
80 Hymus Boulevard  
Pointe Claire, P.Q.  
H9R 1E3  
(514) 695-0460  
TELEX: 05-821633

**TORONTO**  
245 Dalesford Rd.  
Toronto, Ont.  
M8Y 1G4  
(416) 255-5547  
TELEX: 06-967748

**WINNIPEG**  
884 Bradford St.  
Winnipeg, Man.  
R3H 0N5  
(204) 775-8521  
TELEX: 07-57698

**EDMONTON**  
8220 Davies Rd.  
Edmonton, Alta.  
T6E 4N2  
(403) 465-3311  
TELEX: 037-2326

**VANCOUVER**  
2131 Willingdon Ave.  
Burnaby, B.C.  
V5C 5J4  
(604) 294-3461  
TELEX: 04-354754